



Accu-Time Systems, Inc.

# *Cyber Series Biometric User's Guide*

A large, rectangular background graphic with a light gray gradient. It features a complex, repeating pattern of white, stylized geometric shapes, including circles, squares, and crosses, arranged in a grid-like fashion.

- A Biometric Time and Data Collection Terminal -

Copyright

Copyright © 2002. Accu-Time Systems, Inc. All rights reserved.

Information in this document is subject to change without notice. No part of this document may be reproduced or transmitted in any form or by any means, electronic, or mechanical, for any purpose, without express written consent of Accu-Time Systems, Inc.

**Accu-Time Systems, Inc.**

420 Somers Rd.

Ellington, CT 06029 USA

(860) 870-5000

(800) 355-4648

[www.accu-time.com](http://www.accu-time.com)

Trademarks

Accu-Time Systems and the Accu-Time logo are registered trademarks of Accu-Time Systems, Inc.

Rev. CSB-01

---

# Table of Contents

---

<b>Chapter 1. Introduction .....</b>	<b>1-5</b>
<b>Getting Started .....</b>	<b>1-6</b>
Configurations .....	1-6
<b>Specifications .....</b>	<b>1-7</b>
Cyber Ports .....	1-8
Quick Change Reader .....	1-8
Ethernet Card Slot.....	1-8
 <b>Chapter 2. Installation.....</b>	 <b>2-9</b>
<b>General Guidelines.....</b>	<b>2-10</b>
<b>RS232.....</b>	<b>2-11</b>
RS232 Sample Install.....	2-11
<b>RS485.....</b>	<b>2-12</b>
RS485 Modular Sample Install.....	2-12
RS485 Twisted Pair Sample Install.....	2-13
<b>Ethernet.....</b>	<b>2-14</b>
Ethernet Wiring.....	2-14
Ethernet Sample Install.....	2-14
 <b>Chapter 3. Setup and Diagnostics .....</b>	 <b>3-15</b>
<b>Test Mode .....</b>	<b>3-16</b>
Reader Test.....	3-16
Keypad Test .....	3-17
Low Power Test .....	3-17
Serial RS232 Test.....	3-17
Serial RS485 Test.....	3-17
Select Baud Rate .....	3-17
Serial AUX Test.....	3-17
DIDO Test.....	3-17
<b>Setup Mode .....</b>	<b>3-18</b>
Serial Number.....	3-18
Mac Address .....	3-18

---

Comm Port Setup.....	3-19
Bit Rate.....	3-19
Data Bit.....	3-19
Parity.....	3-19
Aux1 Port Setup.....	3-20
Aux1 Device.....	3-20
Clock Address Setup.....	3-20
Host Connect Setup.....	3-20
Reader Setup.....	3-20
RTC Setup.....	3-21
Date Format.....	3-21
Set Date and Time.....	3-21
Daylight Savings.....	3-21
Password Setup.....	3-21
Clear RAM.....	3-21
Downloading.....	3-22
<b>Chapter 4. Troubleshooting.....</b>	<b>4-23</b>
Power Issues.....	4-24
Communication Issues.....	4-24
Reader Issues.....	4-24
Ethernet Issues.....	4-25
Maintenance.....	4-26
<b>FCC Statement.....</b>	<b>4-27</b>

---

CHAPTER 1 ***INTRODUCTION***

---

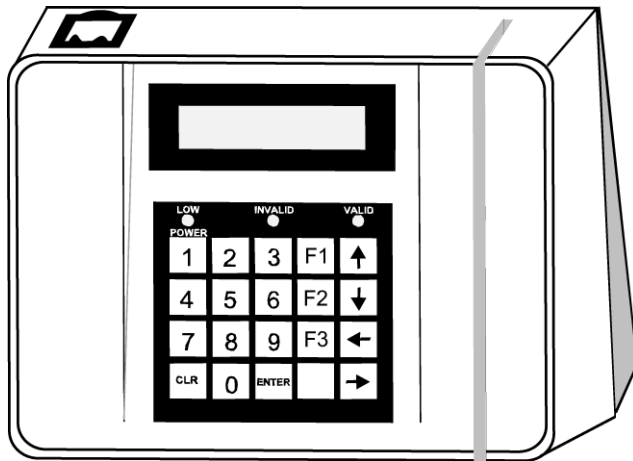

# Getting Started

The Cyber Series Biometric by Accu-Time is designed for workforce management applications which include employee time and attendance for payroll, access control and job tracking. The selectable serial or Ethernet (10/100 BaseT) communications and optional PCMCIA-type slot offer countless configuration options that make the Cyber Series second to none.

## About the User's Guide

The Cyber Series Biometric supports a variety of different features. This manual is separated into chapters that encompass the entire Cyber Series line of terminals and their numerous options. There are hyper linked cross-references throughout this manual, which when clicked, will take the reader to the corresponding page. The expandable guide in the left-hand frame, table of contents, and index all contain hot links for user-friendly navigation. Chapters are comprised of the following elements:

- Installations
- Setup and Diagnostics
- Troubleshooting

## Configurations

The Cyber Series has numerous options. Below is a table detailing the options available with each Cyber Series.

Terminal	Serial	Ethernet		Memory	Flash	Display	DI/DO	Slots	Mounting
		10M	10/100M						
<b>CS1B</b>	Std	-	-	512K	256K	4x20	Opt	-	Lock
<b>CS2B</b>	Std	-	Std	512K	256K	4x20	Opt	-	Lock
<b>CS3B</b>	Std	-	Std	1M	512K	4x20	Opt	1	Lock

An uninterrupted power supply (UPS) is available as an option for each of the Cyber Series' terminals.

**Specifications**

Display:	4 line by 20 character backlit LCD
Clock:	12 or 24 hour format - USA or International time stamp of data transactions
Keypad:	Software defined function keys Large 20 key tactile 4x5 matrix Custom, user-defined keypad legends
Indicators:	Yellow LED = low power Red and green = programmable LEDs Diagnostic LED for Ethernet
Memory:	Up to 1MB and up to 512KB Flash
Programming:	ATS Universal Command Set modules, C programming language or third party custom application packages
Self-Test:	On-board set-up and full-feature diagnostics
Interface:	TCP/IP Ethernet 10/100 baseT 802.3 EIA standard RS232 or RS485 33.6K Baud modem (optional) DI/DO or serial interface printer port (optional)
Enclosure:	Die cast aluminum housing with optional key-lockable base or gull-back mounting
Power:	+10 to +17VDC (+12VDC Nominal) Non-interruptible power source w/charger
Environment:	32 to 110 degrees Fahrenheit (0 to 43 degrees Celsius)
Physical:	7.25" x 9.75" x 3.8" Weight: 6 lbs (18.42cm x 24.77cm x 9.65cm Weight: 2.72kg)
Accessories:	Integrated/external visible/infrared bar code and magnetic stripe track II slot readers Integrated/external proximity readers Solid state or dry contact relay modules Serial interface printer port
Certification:	FCC part 15

## Cyber Ports

View from the back of the Cyber Series Biometric terminal.

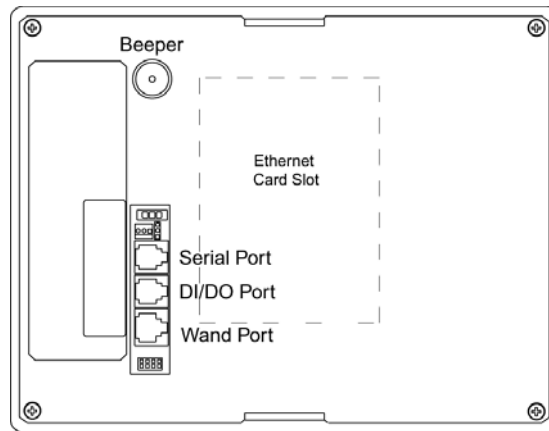

### Quick Change Reader

Notice the location of the Quick Change Reader plate in the figure above. The reader can easily be swapped between a bar code or magnetic stripe reader. This feature allows for greater configuration options without having to disassemble the terminal, which reduces the risk of voiding the warranty. The reader plate is held in place by two hand-tightened, quick-release knobs. To remove the reader, simply unscrew the knobs, gently unplug and pull out the reader.

### Ethernet Card Slot

The Cyber Series Biometric is currently configured for the Ethernet communications option by way of a temporary Ethernet Card Slot. In the figure above, the slot is represented by the dotted line. An Ethernet card is supplied if this option is purchased. Future designs will place Ethernet communications on the main processor board.

Because the Accu-Time policy is one of continuous improvement, look for this Ethernet Card Slot to become an option slot for almost any peripheral.

---

CHAPTER 2 ***INSTALLATION***

---

# General Guidelines

## Environment

Although the ATS Cyber Series Biometric is a durable industrial-grade device, which will endure harsh environments, it never the less is an electronic device. Environmental constraints exist and care should be given when selecting a location for installing and operating the Cyber Series. The terminal is designed to operate indoors. Exposure to outdoor elements such as rain or snow will not only void the manufacturer warranty, but may cause damage to the device.

## Operating Parameters

Accu-Time recommends the Cyber Series Biometric operate in an ambient temperature range of between 32 and 110 degrees Fahrenheit. Non-condensing humidity should be less than 95%. The terminal should be mounted on a vibration-free area.

## Location

Locate a flat wall surface to accommodate the Cyber Series Biometric. With terminal power being supplied locally, insure that a conventional 110VAC wall outlet, 220VAC in Europe and other areas (check local electrical code requirements), is dedicated to accept the Cyber Series 12VDC power pack assembly. The outlet should be no further than four (4) feet from the terminal.

Prepare the wall surface to accommodate mounting hardware with the supplied terminal mounting template. Typical mounting height is forty-eight inches from floor to the terminal display (compliant to the Americans with Disabilities Act). Observe OSHA and/or local safety codes when operating tools during all phases of installation. Attach the terminal to the wall. Select and remove one of the perforated knockouts on the wall mount, which will accommodate the data transmission and 12VDC power pack cable assemblies.

## RS232

The RS232 Cyber Series Biometric must be located no greater than fifty (50) wire-feet from the host computer. EIA standards for RS232 protocol data transmission dictate this cable distance. Exceeding this requirement greatly increases the chances for continual data re-transmission, which may never be acknowledged.

For RS232 applications, ATS recommends using its modular telephone-type data cable. This eight- (8) conductor shielded flat cable has RJ-45 modular plugs on each end. The fifty (50) foot cable, ATS part number (63-2003-02), may run along side base-moldings, walls, overheads, or in hostile environments through conduit tubing. One end of the cable terminates into the Cyber Series serial communication port while the other terminates into the host computer's serial port via an ATS RS232 host communication adapter.

## RS232 Sample Install

The following RS232 sample installation is shown with power supplied locally.

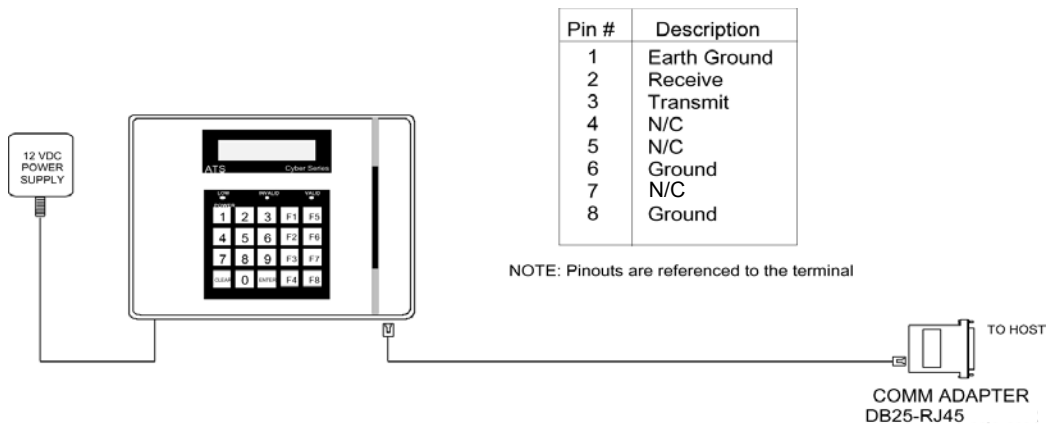

# RS485

The RS485 Cyber Series locally powered must be located no greater than five thousand (5000) wire-feet from the host computer. EIA standards for RS485 protocol data transmission dictate this cable distance. Exceeding this requirement greatly increases the chances for continual data re-transmission, which may never be acknowledged.

RS485 allows for the Cyber Series to be used in multi-dropped networks. Thirty-two (32) terminals can be supported on a single host communication port.

## RS485 Modular Sample Install

If the host is not equipped with an RS485 port, an ATS RS232/485 converter with 12 volt power pack assembly will convert the terminal communication lines to RS232 levels. The host output of the RS232/485 converter plugs directly into the ATS RS232 Communication Adapter.

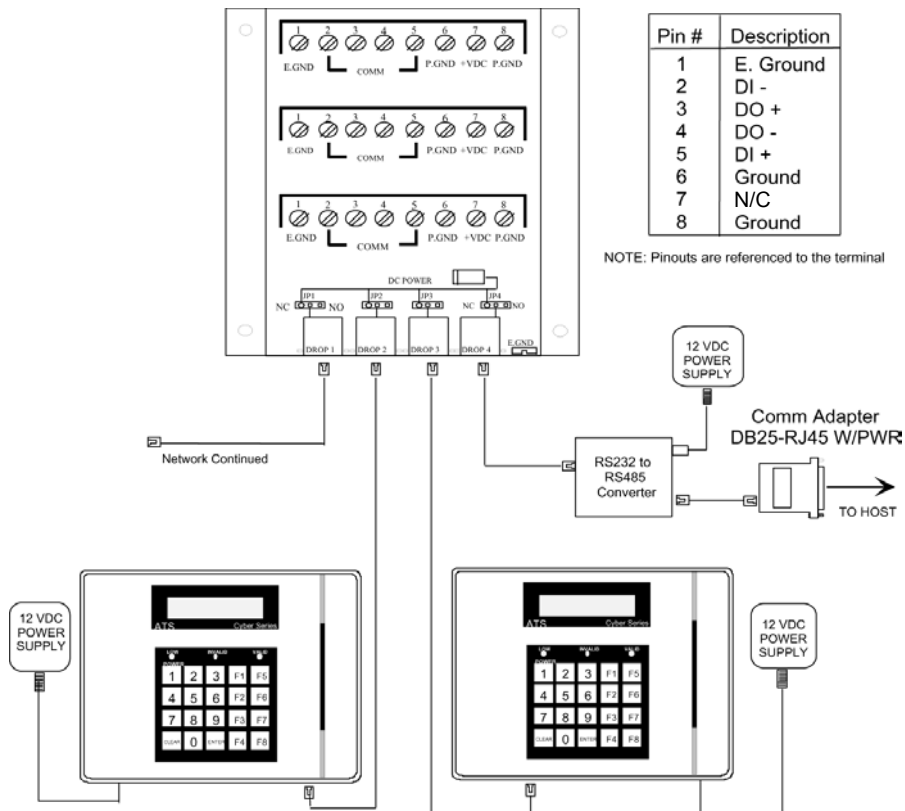

Installation

# RS485 Twisted Pair Sample Install

The sample install below involves twisted pairs screwed-down with power being supplied remotely.

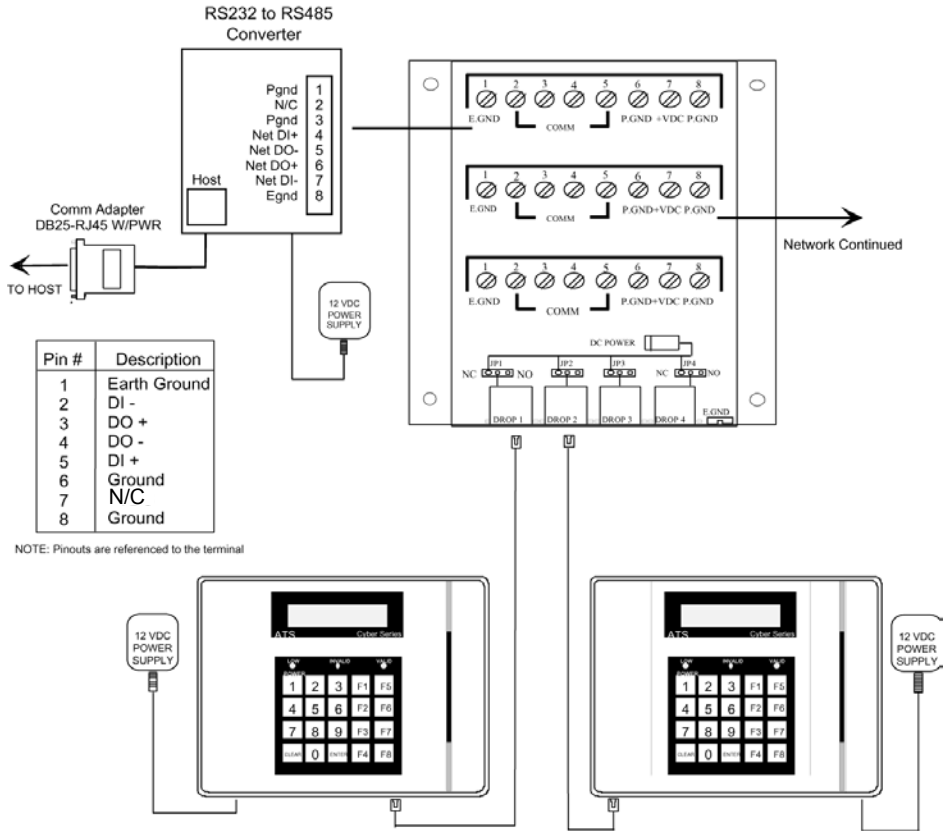

Installation

## RS485 Data Cable Specifications

For RS485 communication applications, ATS recommends using a data transmission cable that adheres to the following specifications:

- Five conductor shielded 24-gage wire with a drain.
- The impedance of the cable should be 100 Ohms.
- The capacitance should be 12 pico-farads per foot.
- The jacket of the cable is typically either a PVC or Plenum material.

# Ethernet

The Ethernet Cyber Series Biometric may be located at any point within a TCP/IP Ethernet 10/100baseT network, providing the single segment length from the network hub does not exceed three hundred and twenty-eight (328) wire-feet. A typical topology for the Cyber Series in an Ethernet 10/100baseT network is a star configuration.

## Ethernet Wiring

For Ethernet communication applications, ATS recommends using a Category 5 unshielded twisted pair high speed data transmission cable. One end of the 568B RJ45 terminated cable is plugged into the Cyber Series Ethernet communication port, while the other end is plugged into the network hub.

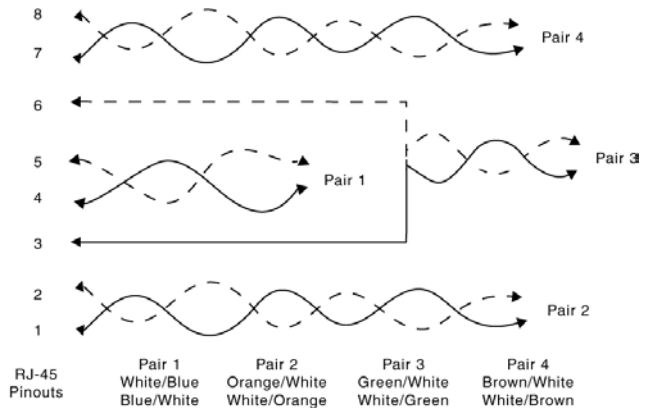

## Ethernet Sample Install

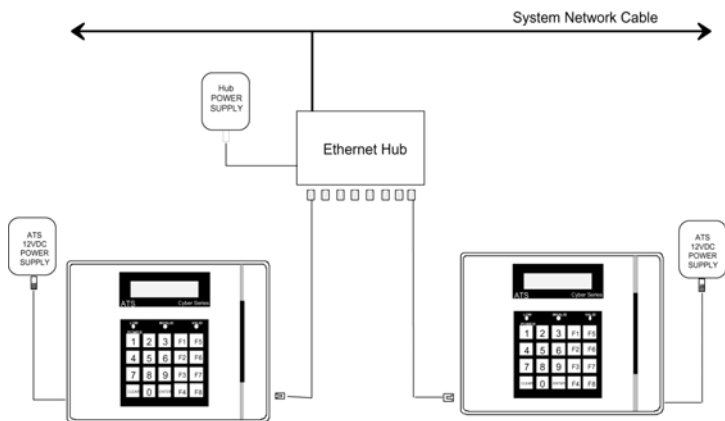

Installation

---

CHAPTER 3 ***SETUP AND  
DIAGNOSTICS***

---

# Test Mode

The Test Mode is used to run a diagnostic check on the terminal. This should be done when first setting up the terminal.

## Power Up

To power up the Cyber Series, an ATS 12VDC power supply must be applied locally to the terminal. Refer to *General Guidelines* on page 2-10 for more information. The Cyber Series beeps, executes a power up sequence, and displays the idle prompt.

To access the Test Mode:

- Hold down both the Enter and Clear keys. The display should resemble the following:

```

ATS TSD MODE
_Enter Test Mode
  
```

- Press the Clear key to cycle through the Test, Setup or Diagnostics Mode prompts.
- Upon entering the Test Mode, the display is tested and functional when all of the characters are lit. Press the Clear key to continue on with the Test Mode.

## Keypad legend



The **CLEAR** key: Jumps to the next test prompt.

The **ENTER** key: Jumps to the previous test prompt.

## Reader Test

Press the Enter key to perform the reader or wand test. The display will resemble the following:

```

Test Reader or Wand
-----
  
```

Swipe a badge or scan with a wand to test. To exit this Test Mode parameter, press the Clear key. Press the Clear key to advance to the Keypad Test.

---

**Keypad Test**

Press the Enter key at the “Test Keypad” prompt. Exit the Keypad Test by pressing the Clear key.

**Low Power Test**

Press the Enter key to test the terminal’s power. Press the Clear key to exit this test.

**Serial RS232 Test**

This parameter performs a test on the RS232 communications. The terminal will beep during testing (press 1 on the keypad to disable beep). Press the Clear key to exit this test.

**Serial RS485 Test**

This parameter performs a test on the RS485 communications. The terminal will beep and flash the green valid LED during testing (press 1 on the keypad to disable beep). Press the Clear key to exit this test.

**Select Baud Rate**

The baud rate for the modem test may be selected by punching the 1, 2, or 3 key on the keypad that corresponds to the appropriate baud rate. Press the Clear key to exit.

1= 24

2= 96

3= 19.2

**Serial AUX Test**

This parameter performs a test on the serial AUX port. This test is defaulted to perform an internal loop-back (F1 key). The F2 key performs an external loop-back, which requires a loop-back connector. If one is not provided, the test will fail. Press the Clear key to exit.

**DIDO Test**

This parameter performs a test on the DIDO port. This test is defaulted to perform an internal loop-back (F1 key). The F2 key performs an external loop-back, which requires a loop-back connector. If one is not provided, the test will fail. Press the Clear key to exit.

Press the Enter key to continue on to the Setup Mode.

## Setup Mode

The Setup Mode allows the operator to configure the terminal for communications with the host computer. The Cyber Series Biometric default parameters are as follows:

- Baud Rate            9600
- Parity                Odd
- Address              01
- Data bits            7
- Terminal            A  
  application type

To enter the Setup Mode, press the Enter key when prompted. The display will resemble the following:

ATS TSD MODE  
\_Enter Setup Mode

Once in the Setup Mode, scroll through the setup options by pressing the Clear key. To select a parameter, press the Enter key.

### Keypad Legend

The **CLEAR** key: Acts as a backspace for errors in keyed input. This key also jumps to the next setup prompt.

The **ENTER** key: Selects the input.

## Serial Number

The serial number of the terminal is displayed here. Press the Clear key to advance (for factory use).

## Mac Address

The Mac address of the terminal is displayed here. Press the Clear key to advance (for factory use).

---

## Comm Port Setup

Press the Enter key to setup the communication port. The display will resemble the following:

```
SETUP COMM PORT
RS232 9600 7 ODD
```

Pressing the Clear key will scroll through the options wherever the cursor is placed. Press the Enter key to accept either **RS485** or **RS232** communications and advance to the Bit Rate parameter.

### Bit Rate

Press the Clear key to scroll through the following options (in bits/second).

```
1200
2400
4800
9600
14400
19200
28800
38400
56700
115200
```

Press the Enter key to accept the value and advance.

### Data Bit

Press the Clear key to scroll through **7** or **8** data bits. Press the Enter key to accept the value displayed and advance to the Parity parameter.

### Parity

Press the Clear key to scroll through the parity options: **odd**, **even**, or **none**. Press Enter to select the value. Press the Clear key to advance.

---

## Aux1 Port Setup

Press the Enter key. Press the Clear key to scroll through the following baud rate options:

**9600**  
**14400**  
**19200**  
**28800**  
**38400**  
**57600**  
**115200**

Press the Enter key to accept the value displayed.

## Aux1 Device

Set up the device by pressing the Clear key to scroll through the following options: **modem**, **printer**, **fingerprint reader (N/A)**, and **finger geometry reader (N/A)**.

## Clock Address Setup

Press the Enter key to setup the terminal address. Scroll through the application types by pressing the Clear key (**A-J**). Press the Enter key to accept the value and Clear to advance.

## Host Connect Setup

Press the Enter key to setup the host connection. Press the Clear key to scroll through the following types:

- **Serial**
- **Static TCP/IP**
- **DHCP**

Press Enter to select the desired host connection. Press the Clear key to **Disable** or **Enable** the modem and press Enter to accept the value. Press the Clear key to advance to the Reader Setup.

## Reader Setup

Press the Enter key to setup the reader. Press the Clear key to step through the following options: **Optical/Magnetic** or **Wiegand**. Press the Enter key to select and the Clear key to advance.

---

## RTC Setup

Press the Enter key to setup the RTC (Real Time Clock) chip. The display will prompt to “Select Date Format”.

### Date Format

Scroll through the date formats by pressing the Clear key. Press the Enter key at the desired format.

- MM/DD/YY
- YY/MM/DD
- DD/MM/YY

### Set Date and Time

To set the date and time, press the corresponding numbers on the keypad. Press the clear key to skip spaces. Press the Enter key to accept the entry and advance to the Daylight Savings parameter.

### Daylight Savings

Press the Clear key to select either **Enable** or **Disable**. Press the Enter key to accept the entry and exit. Press the Clear key to advance.

## Password Setup

Press the Clear key to setup the password. This prompt is optional until the password is set. Enter in the numeric password (7 digit max.). The next prompt will confirm the password. Press the Enter key to accept the value and continue.

## Clear RAM

To clear the terminal’s memory, press the Enter key. Press Enter at the alert prompt to proceed or the Clear key to cancel.

At this point, the terminal setup is complete. Press the Enter key at the Exit Setup prompt to continue on to the Diagnostics Mode. To exit the Setup Mode, press the Enter key at the “Exit Setup” prompt. To then exit the Test Mode, scroll through the parameters until the display resembles the following:

ATS TSD MODE

\_Exit Test Mode

Press the Enter key and the terminal will return to the idle prompt.

---

## Downloading

The Cyber Series Biometric, when used with a time and data collection application, can be downloaded with employee names, badge numbers, schedules, etc. Download commands are explained in the Universal Command Set manual. Refer to this manual for further information.

---

CHAPTER 4 ***TROUBLESHOOTING***

---

---

## Power Issues

**The terminal does not power up. The display and none of the status LEDs are lit.**

Ensure that the primary side of the DC power pack assembly is plugged into a live AC outlet. Ensure that the secondary side of the DC power pack output cable is plugged into the mating three prong port on the back of the Cyber Series.

Test the outlet by plugging in another electronic device.

If all else fails, try replacing the power pack assembly.

Note: If the battery backup option is installed, the terminal will operate for approximately 1.5 hours when the primary voltage source is lost. After this, the terminal will power off. The yellow indicator LED, located on the front of the terminal, will illuminate while operating in the battery backup mode.

**The yellow ‘Low Power’ indicator LED is illuminated.**

Check the main AC voltage. This indicator signifies that the terminal is no longer operating on the power pack.

If the terminal display does not go blank after unplugging the battery connector, unplug and replace the power pack assembly.

## Communication Issues

**The terminal is not communicating with the host.**

Verify that the terminal-to-host communication cable is not defective or unplugged on either end. Ensure that cable termination guidelines and lengths are observed.

Ensure that the application package is loaded and running on the host.

Ensure that the communication parameters for the terminal and the host coincide. Refer to the *Setup Mode on page 3-18* for terminal default parameters.

## Reader Issues

**Terminal does not accept badge data.**

Refer to the badge vendor’s specifications to ensure that the badge was manufactured properly.

Ensure that the badge media is facing the right direction when swiped.

The badge reader may need cleaning. Swipe a pre-moistened (isopropyl alcohol) cleaning card through the reader several times.

The badge number may not exist in the validation file. See supervisor.

**Terminal does not accept keypad input.**

The keypad connector may be unplugged or the keyed data may not exist in the validation file. See supervisor.

If all solutions have been explored and the problem still exists, contact the Accu-Time Product Service Department at (860)870-5000 during normal working hours (9am to 5pm Monday through Friday). Prior to contacting Accu-Time, please have available the serial number and, if possible, the configuration number of the product.

Note: The Accu-Time terminal must be operated within the parameters included in this manual. Any operation performed contrary to these parameters will void the warranty.

## Ethernet Issues

### The terminal is not communicating with the host.

The communication parameters may not have been previously set. Place the terminal in the Test Mode. (*This parameter not yet supported.*) The network administrator should provide the following:

- IP address to be assigned to the terminal
- IP address of the host to which the terminal can connect
- Network Mask (example: 255.255.255.0)
- Gateway or router address (if required)

If the parameters are set, exit the Test Mode and perform a Ping on the terminal.

Verify that the cable is plugged into both ends (terminal and hub) and terminated to the appropriate eight (8) position modular connector. Refer to *Ethernet on page 2-14*.

Verify that the single segment cable length is equal or less than the specified 328 feet. The cable should also be a 10/100base-T category 5, twisted pair, high-speed data transmission cable with both ends properly crimped.

Insure the application package is loaded and running on the host.

Insure that all connections are made and that the host software application is functional. If possible, take a known working terminal, re-address it for this particular node and determine if the problem is related to the terminal, installation, or host.

If neither the standard nor Ethernet troubleshooting guide is of any help, please contact the Accu-Time Product Service Department, (860) 870-5000, for further assistance.

## Maintenance

The Cyber Series is a maintenance-free data collection device. The only required procedure is periodic cleaning of the badge reader.

To clean the badge reader, swipe a pre-moistened (isopropyl alcohol) cleaning card through the reader several times. Low usage readers should be cleaned monthly. High usage readers should be cleaned weekly.

---

## FCC Statement

This equipment has been tested and found to comply with the limits for a Class B digital device pursuant to Part 15 of the FCC rules. These limits are designed to provide reasonable protection against harmful interference in a residential installation. This equipment generates, uses, and can radiate radio frequency energy and, if not installed and used in accordance with the instructions, may cause harmful interference to radio communications. However, there is no guarantee that interference will not occur in a particular installation. If this equipment does cause harmful interference to radio or television reception, which can be determined by turning the equipment off and on, the user is encouraged to try to correct the interference by one or more of the following measures:

- Reorient or relocate the receiving antenna.
- Increase the distance between the terminal and the receiver.
- Connect the equipment into an outlet on a circuit different from that which the receiver is connected.

*FCC Warning:* To assure continued FCC emission limit compliance, the user must use only the recommended shielded interfacing cable when connecting to a host computer. Also, any unauthorized changes or modifications to this equipment would void the user authority to operate this device.

---

# Index

---

- A**
- Address 3-18
- B**
- Baud Rate 3-18
  - Bit Rate 3-19
- D**
- Data Bit 3-19
  - Defaults
    - Address 3-18
    - Baud Rate 3-18
    - Parity 3-18
    - Terminal Application Type 3-18
  - Downloading 3-22
- E**
- Ethernet 2-14
    - Issues 4-25
    - Sample Install 2-14
    - Wiring 2-14
  - Ethernet Card Slot 1-8
- I**
- Install
    - Ethernet 2-14
      - Sample 2-14
      - Wiring 2-14
    - RS232 2-11
    - RS232 Sample 2-11
    - RS485 2-12
      - Cable Specifications 2-13
      - Twisted Pair Sample 2-13
    - RS485 Sample 2-12
- M**
- Maintenance 4-26
- P**
- Parity 3-18–3-19
  - Ports 1-8
- Q**
- Quick Change Reader 1-8
- R**
- RS232 2-11
    - Sample Install 2-11
  - RS485 2-12
    - Cable Specifications 2-13
    - Sample Install 2-12
    - Twisted Pair Sample Install 2-13
- S**
- Setup Mode 3-18
    - Aux1 Port Setup 3-20
      - Aux1 Device 3-20
    - Clear RAM 3-21
    - Clock Address Setup 3-20
    - Comm Port Setup 3-19
      - Bit Rate 3-19
      - Data Bit 3-19
  - Installation
    - Environment 2-10
    - Location 2-10
    - Operating Parameters 2-10
  - Issues
    - Communication 4-24
    - Ethernet 4-25
    - Power 4-24
    - Readers 4-24

---

- Parity 3-19
- Host Connect Setup 3-20
- Mac Address 3-18
- Password Setup 3-21
- Reader Setup 3-20
- RTC Setup 3-21
  - Date Format 3-21
  - Daylight Savings 3-21
  - Set Date and Time 3-21
- Serial Number 3-18

## **T**

- Terminal 1-8
  - Configurations 1-6
  - Specifications 1-7
- Terminal Application Type 3-18
- Test Mode 3-16
  - DIDO Test 3-17
  - Keypad Test 3-17
  - Low Power Test 3-17
  - Reader Test 3-16
  - Select Baud Rate 3-17
  - Serial AUX Test 3-17
  - Serial RS232 Test 3-17
  - Serial RS485 Test 3-17