

SERIES 3610

ENVIRONMENTALLY SEALED TIME AND DATA COLLECTION TERMINAL



Accu-Time Systems, Inc.
420 Somers Road, Ellington, CT 06029
Tel: (860) 870-5000 Fax: (860) 872-1511
Web Site: www.accu-time.com



Copyright® 1998 Accu-Time Systems, Inc. Second printing 2002. Accu-Time is a registered trademark of Accu-Time Systems, Inc. The material contained in this manual is subject to change. No part of this manual may be reproduced or distributed in any form or by any means, or stored in any database or retrieval system, without Accu-Time's prior written permission. Accu-Time Systems, Inc. makes no warranty of any kind including, but not limited to, any implied warranties of merchantability, and fitness for a particular purpose in regard to this manual.

All Rights Reserved. Printed in the USA.

ACCU-TIME® SERIES 3610

TABLE OF CONTENTS

Introduction	1
Features	2
Specifications	3
Installation	4
ACCU-RATE™ Diagnostics	9
Maintenance	14
Troubleshooting Guide	15

INTRODUCTION

The Accu-Time Series 3610 is a NEMA 4X rated environmentally protected, true “C” programmable Time and Data Collection Terminal. The durable enclosure insures protection in an indoor/outdoor time and data collection environment. The Series 3610 offers a large user memory base of 128K for file validation, local editing and scheduling functions. Among the many features of the Series 3610 are:

Multi-Media: Can support most standard bar code formats including UPC, 128, 39, 2/5, 12/5 and more.

Flexibility: The Series 3610 can act as a stand-alone time station or as part of a local or wide area network. The terminal can also interface with virtually any host hardware or software platform.

Custom Applications: Custom programs and programmable function keys can provide users with the flexibility to create a variety of options.

Reliability: A Real Time Clock (RTC) provides 12 or 24-hour time formats with quartz precision. An optional uninterruptible power supply (UPS) provides terminal operation for up to 4 hours during power outages. Data storage will be preserved for up to 4 days with the internal memory backup system.

Durability: The NEMA 4X enclosure protects circuitry from environmental conditions such as splashing water, windblown dust, and rain. The housing remains undamaged by the formation of ice and, in addition, is corrosion-resistant. The NEMA 4X rating signifies a watertight and dust-tight seal. Optional terminal heaters are available, which allows the device to withstand temperatures ranging from -25° to 110° Fahrenheit. (Normal operating temperature range without heater option(s) is 32° to 110° F.)

Versatility, Reliability and Affordability in a state-of-the-art ergonomically designed terminal and backed by the ACCU-TEAM.

FEATURES

- ◆ Single or multi-clock environments on a variety of host platforms with application programs integrating the ATS DATA TRAKER™ family of modules
- ◆ Molded fiberglass polyester, NEMA type 4X, sealed environmental housing for indoor/outdoor use
- ◆ 128K Byte memory base (capacitor backed), optional 32K Byte “Flash” memory
- ◆ EIA Standard RS232 or RS485 compatible
- ◆ On-board ACCU-RATE™ terminal set-up and diagnostics package
- ◆ Custom keypad legends with software defined function keys
- ◆ Large 20 key tactile 4x5 matrix keypad
- ◆ 4 line x 20 character liquid crystal backlit display
- ◆ Audible annunciator
- ◆ Visible/infrared bar code slot reader, externally mounted or integrated onto a mounting plate
- ◆ Dual DI/DO ports and an Auxiliary Serial Interface port
- ◆ Low voltage power source locally or remotely supplied
- ◆ Non-interruptible power source with on-board charger
- ◆ FCC part 15 Certified

SPECIFICATIONS

Display:	4 Line x 20 Character backlit super-twist LCD
Clock:	12 or 24 hour-format-USA or International (quartz precision) Time stamp of data transactions
Indicators:	Yellow Low Power Indicator, Red and Green programmable indicators
Memory:	128K Byte of capacitor backed memory (i.e. 600-employee base-program dependent) 32K Byte of "Flash" memory (optional)
Programming:	ATS DATA TRAKER™ modules, "C" programming language or third party custom application packages
Interface:	EIA Standard RS232 or RS485 (2 or 4 wire) Dual DI/DO port and Auxiliary Serial Interface port
Enclosure:	Molded fiberglass polyester, sealed environmental housing for indoor/outdoor use NEMA 4X approved
Power:	+10 to +17VDC (+12VDC @ 250 milliamps Nominal) Local, remote or centrally powered Non-interruptible power source with charger (optional) <i>(Optional heater(s) will require additional power – consult factory)</i>
Environment:	Operation: 32° to 110° F (0° to 43°C) Optional heater kits: -25° to 110° F (-32° to 43°C)
Certification:	FCC part 15
Physical:	8.5" wide x 6.25" high x 10.5" deep; weight 8.6 pounds (21.6 cm wide x 15.9 cm high x 26.7 cm deep; weight 3.9 kg)
Accessories:	Integrated (via mounting plate)/External visible/infrared weather resistant Bar Code slot readers Solid State or Dry Contact relay modules

INSTALLATION

GENERAL INSTALLATION GUIDELINES

Environment

The Series 3610 Time and Data Collection Terminal is a durable industrial-grade device, which will endure harsh environments. The ATS terminal is designed to operate indoors and outdoors. The NEMA 4X enclosure serves as a safeguard against splashing water, rain, windblown dust, and hose directed water. The Series 3610 may operate with an internal heater element allowing functionality up to 110° and down to -10° Fahrenheit. With a second heater option, the temperature range expands to -25° Fahrenheit.

The terminal should be mounted on a vibration free area. Select a location, which has adequate lighting and accessibility to operate the terminal safely.

Operating parameters

The RS232 Series 3610 must be located no greater than fifty (50) wire-feet from the host computer. EIA standards for RS232 protocol data transmission dictate this cable distance. Exceeding this requirement greatly increases the chances for continual data re-transmission, which may never be acknowledged.

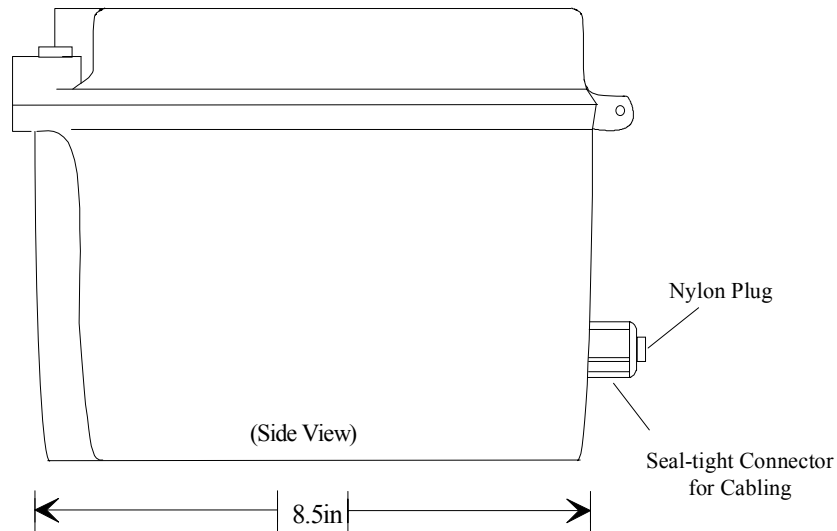

INSTALLATION

The Series 3610 is an environmentally sealed device; therefore all cables supporting the peripheral devices, communications and power sources must be inserted through the appropriate watertight connectors. Observance to this requirement will ensure watertight integrity and protection against external elements.

- ♦ **Mounting:** The case and hinged front cover are made from durable fiberglass polyester. The sealed terminal comes with four plastic mounting ears. These ears should be secured to the bottom underside of the enclosure and extend out from the sides to allow for wall mounting. A special mounting plate is available if an integrated reader is purchased.
- ♦ **Cabling:** A twisted pair or category 5 style *round* cable is required. Select the appropriate seal tight connectors and remove the nylon plugs to accommodate data transmission and 12VDC power pack cable assemblies. The cable is passed through the seal tight connector that is then tightened down over the cable. One seal tight connector per cable is allotted (see diagram below). The supplied rubber tubing should be slid over any cable if the seal tight connector does not clamp the cable securely. This should be done before tightening the connector.
- ♦ **Power:** When terminal power is being supplied locally, insure that a conventional 110VAC-wall outlet, 220VAC in Europe and other areas, (check local electrical code requirements) is available to accept the Series 3610 power pack assembly. The outlet should be no further than four (4) feet from the terminal.
- ♦ **Base:** Locate a flat wall surface to accommodate the Series 3610. Typical mounting height is forty-eight inches from floor to the terminal display (Compliant to the Americans with Disabilities Act). Observe OSHA and/or local safety codes when operating tools during all phases of installation. Attach the four terminal mounting ears (or mounting plate) to a flat wall surface.

For RS232 communication applications, one end of the communication cable terminates into the Series 3610 communication port while the other terminates into the host computer's serial port via an ATS RS232 Communication Adapter. For remote powering, a Network Junction Box or Network Junction Box Jr. could be used.

RS232 INSTALLATION

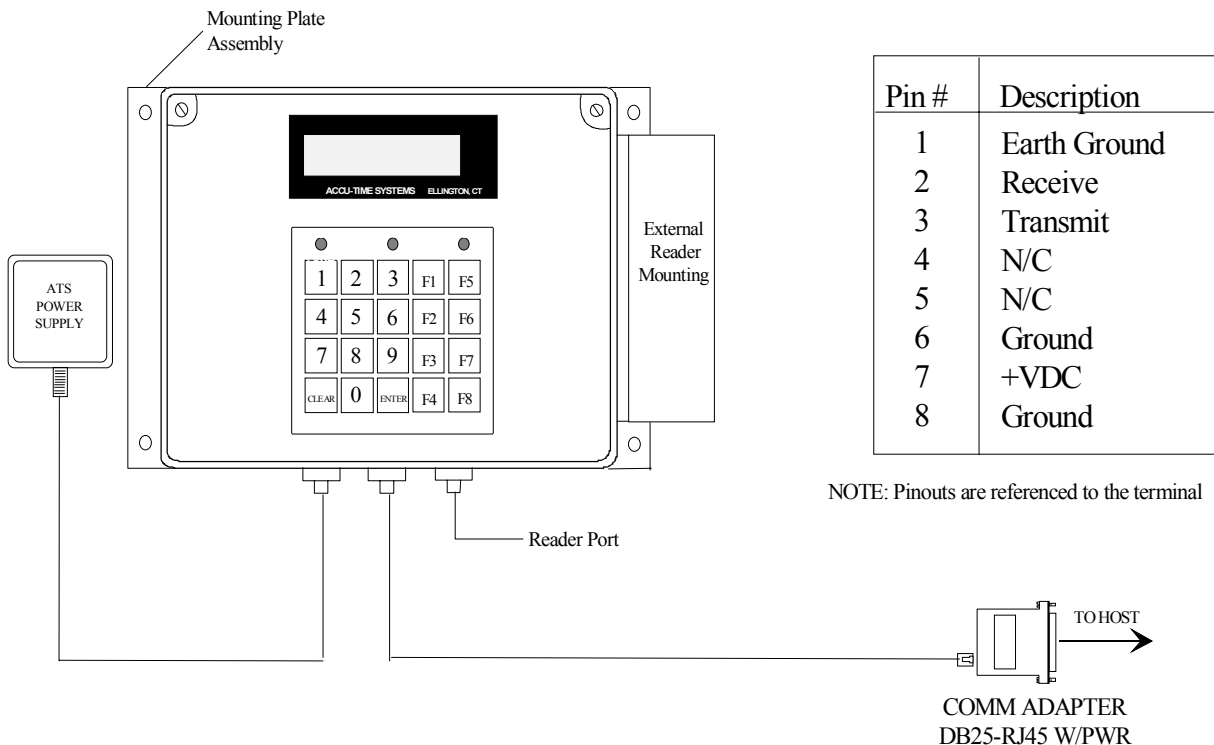

For RS485 Communication applications, ATS® recommends using a **round** data transmission cable that adheres to the following specifications:

- Five conductor shielded 24-gage wire with a drain.**
- The impedance of the cable should be 100 Ohms.**
- The capacitance should be 12 pico-farads per foot.**
- The jacket of the cable is typically PVC material.**

Note: If the host is not equipped with an RS485 port, an ATS® RS232/485 Converter with a 12-volt power pack assembly will convert the terminal communication lines to RS232 levels. The host output of the RS232/485 Converter plugs directly into the ATS® RS232 Communication Adapter.

RS485 allows for the Series 3610 to be used in multi-dropped networks. Thirty-two (32) terminals can be supported on a single host communication port. The use of ATS® Series 1000 Network Controllers allows up to five hundred and twelve (512) terminals on a single host communication port.

MULTI-CLOCK - RS485 INSTALLATION

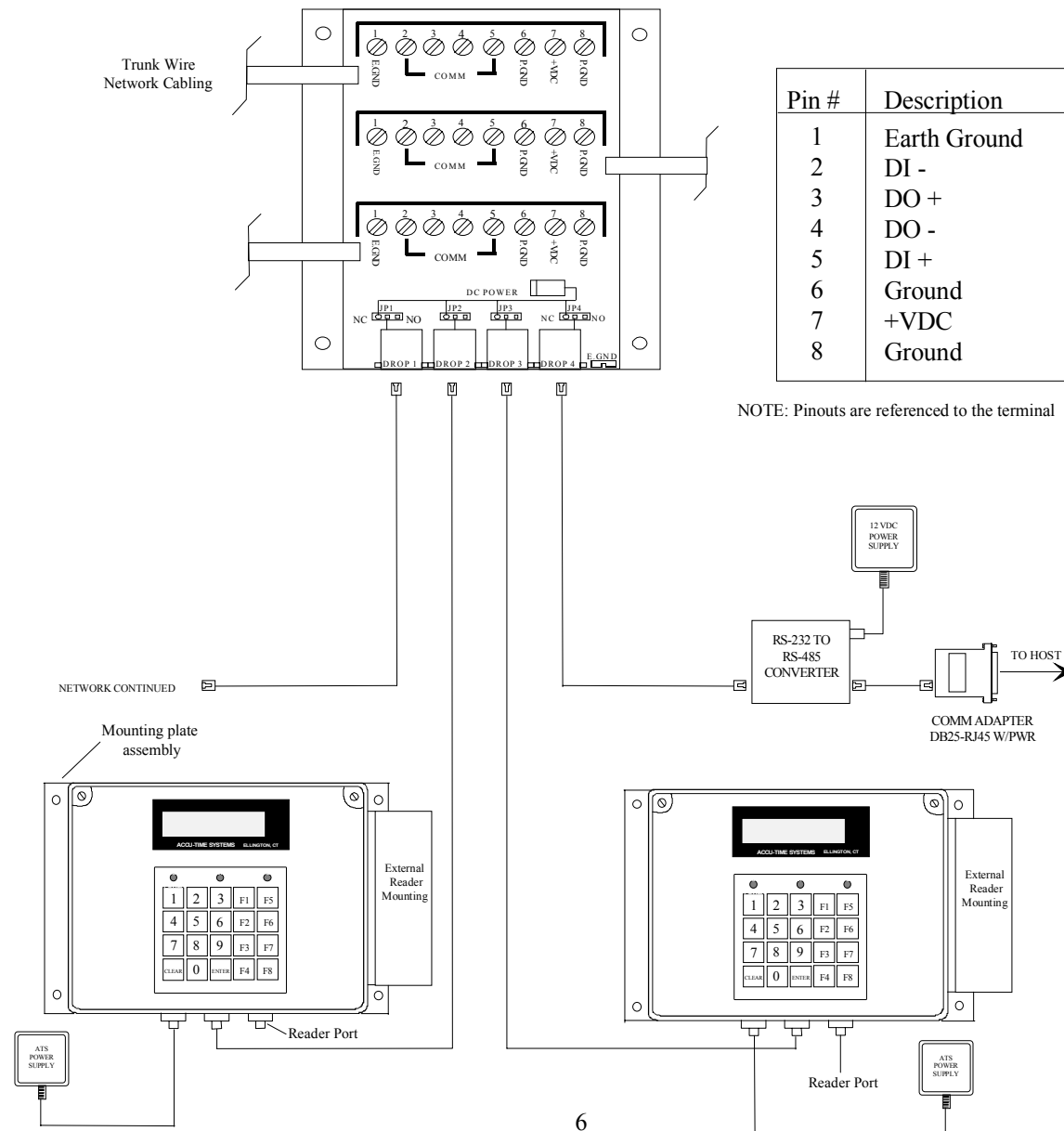

Terminal Cabling

Select and remove the seal tight connector(s) and corresponding nylon plug(s) located on the **outside** of the housing. Remove the hinged cover and pass the data cable through the appropriate seal tight connector. Secure the data cable to the interface board in the base of the Series 3610 terminal (Figure 2). Tighten the seal tight connector down over the cable. Attach the output of the 12VDC power pack assembly (if power is not combined within the communication cable) into the power jack (PJ1) in the base of the Series 3610. The supplied rubber tubing should be installed if the seal tight connectors do not properly secure either cable. Place the jumper, located at JP1 on the I/O board, to the NC position (Figure 2). Plug the primary of the power pack assembly to a conventional wall outlet.

With the terminal's Use/Test switch in the Use mode (Figure 1), replace the enclosure's hinged cover.

The Series 3610 will power-up and display the on-line default message. (*Refer to the ATS SETUP MODE section of this manual for terminal communication setup parameters.*) Attach the remaining end of the data cable into the host computer port. The Series 3610 is now ready for operation.

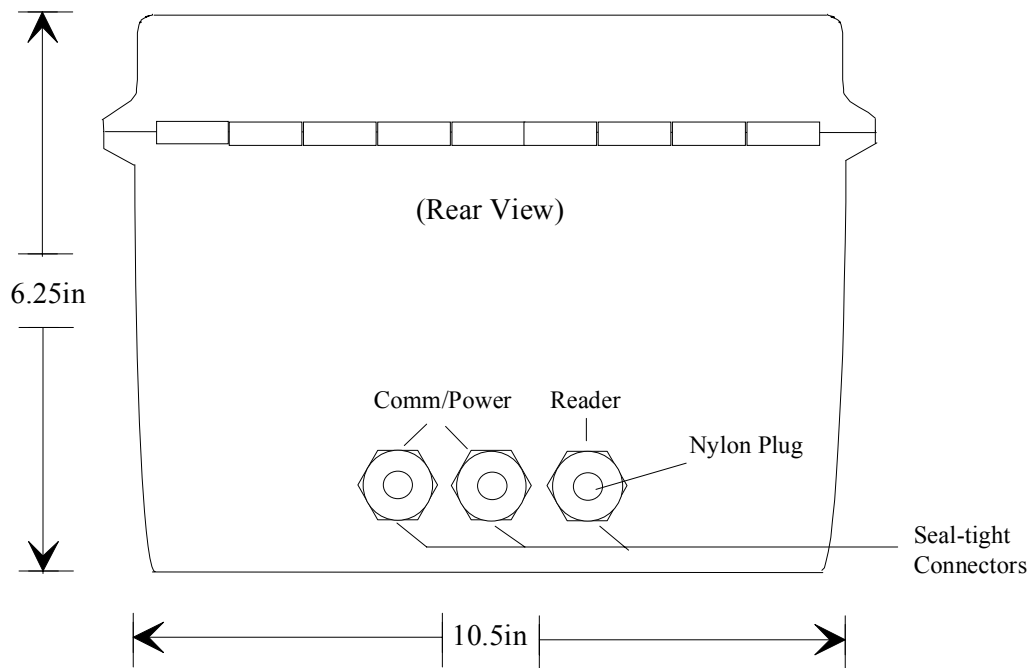

RS232/485 Communication Cabling

Figure 1

Inside of Hinged Cover

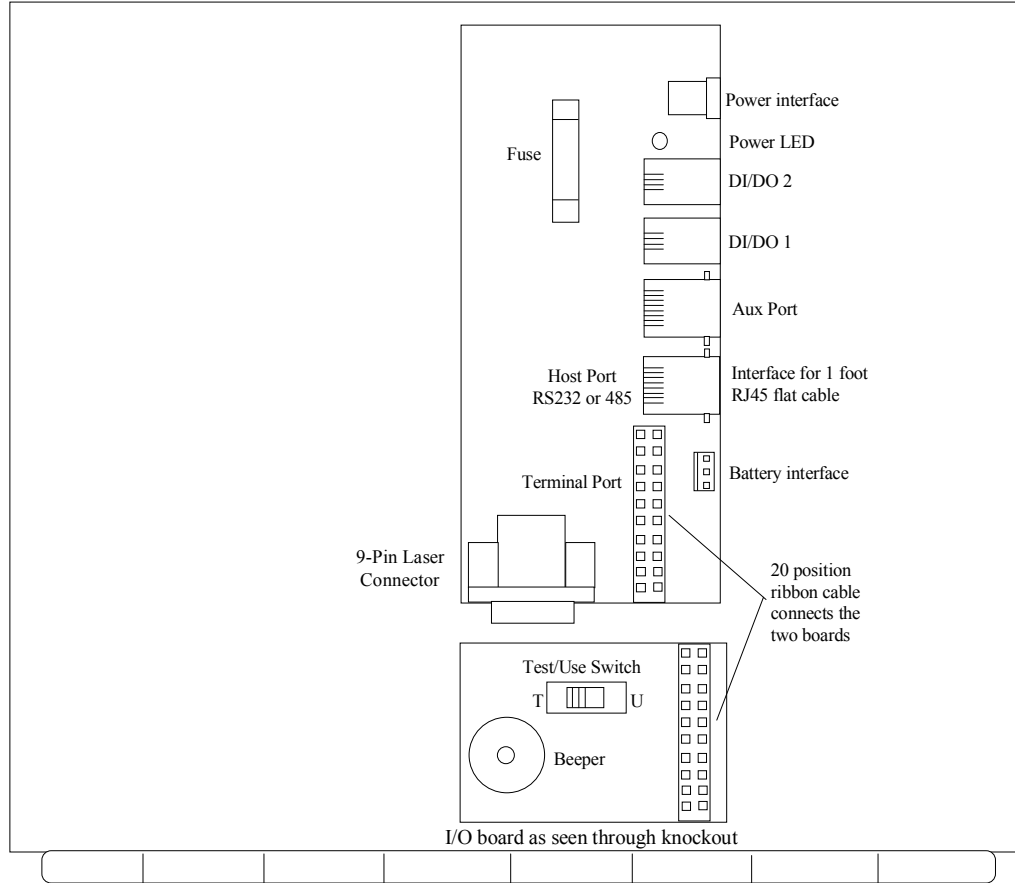
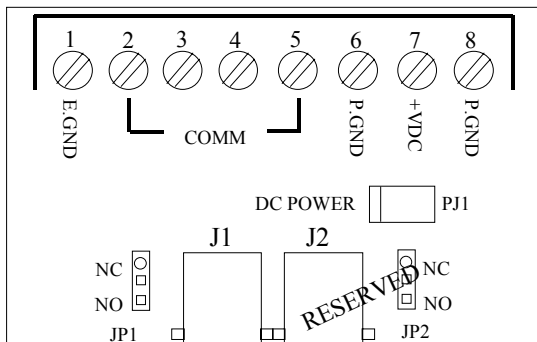

Figure 2

RS232/485 Communication Board



Located in base of terminal enclosure.

- Screw down RS232 or RS485 communication cable to terminal block.
- If power is not supplied through the communication cable, plug power into PJ1. Ensure that the jumper (JP1) is placed in the NC position.
- If power is supplied through communication means, the jumper (JP1) should be placed to the NC position.
- One end of the 1 foot RJ45 flat cable terminates into J1 while the other plugs into the Host port pictured above in Figure 1.

ACCU-RATE™ SET-UP AND DIAGNOSTICS

POWER UP

To power up the Series 3610 a 12VDC source must be applied to the terminal power jack (PJ1 shown in Figure 2). The Series 3610, with the Test/Use switch placed in the Use mode, beeps, executes a power up sequence and displays the message “**TERMINAL LOCKED**”.

ACCESSING TEST MODE

To access the Test mode:

- 1) Unscrew and lift the hinged cover to fully access the terminal.
- 2) Locate the Test/Use switch on the underside of the hinged cover. Slide the switch into the Test position (away from the ribbon cable). The Series 3610 displays “**ATS TEST MODE**”.
- 3) Replace the hinged cover.
- 4) By pressing the CLEAR key, the user can step through the selections.

**NOTE:* Test mode may be exited at any time by placing the Test/Use switch back to the Use position and pressing the CLEAR key.

SELECTIONS:

- ◆ **ATS TEST MODE:** Tests the keypad, display, memory, real time clock, or bar code reader.
- ◆ **ATS SET-UP MODE:** Configures the communication parameters—Baud Rate, Parity Bit, Terminal Address, and Terminal Application Type.
- ◆ **ATS NETWORK TEST:** Performs a terminal to host communication loop-back test. Verifies integrity of cabling.
- ◆ **ATS BATTERY TEST:** Checks terminal battery backup option.
- ◆ **ATS DI-DO TEST:** Checks the Digital Input/Digital Output port by performing a loop-back test.
- ◆ **ATS RESTART MODE:** Resets the terminal, clears all data from memory and performs a power-up sequence.
- ◆ **ATS AUX PORT TEST:** Checks the auxiliary DI/DO and bi-directional serial auxiliary port.

ATS TEST MODE

ATS TEST MODE checks the functionality of the terminal Keypad, Memory, Real Time Clock, and Bar Code reader.

The message “**ATS TEST MODE**” appears on the top line of the display. The 2nd line of the display indicates the program (EPROM) number. To enter the TEST MODE, press the ENTER key. The following information appears:

ATS TEST MODE (XXX) (YY)

The display shows “**ATS TEST MODE**” on the top line followed by two sets of numbers. The first number (XXX) indicates the amount of memory installed (in Kilobytes). The right most number (YY) indicates the terminal Real Time Clock incrementing in seconds (00-59).

Testing the Keypad

At this time the user may test the keypad assembly. The hinged cover must be reattached to the enclosure for this test to be performed. Each time a key is pressed the terminal will beep and the key value will appear on the 2nd line of the display. Press the ENTER key. The message “KEY INPUT ACCEPTED” is displayed. Each time the ENTER key is pressed an internal test of the terminal’s communication port is performed. If an error is detected the message “COMM PORT FAIL” will display, the invalid light will flash and the negative acknowledgement beeper tone will cycle. This message will continue until power is removed from the terminal. Refer to the Troubleshooting Guide of this manual for adjustment.

Testing the Badge Reader

ATS TEST MODE accepts input from slot readers. To test the reader, simply swipe the applicable bar code badge. The terminal beeps and displays the badge data.

To proceed to the ATS SETUP MODE press the CLEAR key.

ATS SETUP MODE

ATS setup mode allows the operator to configure the terminal for communications with the host computer. The Series 3610 default parameters are set as follows:

Baud Rate	9600
Parity	ODD
Address	01
Terminal Application Type	A

To enter the ATS SETUP MODE, press the Enter key at the “ATS SETUP MODE” display prompt. (Prior to pressing the ENTER key, the 2nd line of the display will indicate the current terminal setup values.)

Baud Rate

To change the terminal baud rate:

1. Press the CLEAR key to step through the baud rate choices:

19200
9600
4800
2400
1200
M1200 (Not applicable)
M2400 (Not applicable)

2. When the desired baud rate is displayed, press the ENTER key to store the value and advance to the next parameter.

NOTE: No modem is installed, therefore, if the modem baud rate is selected, the modem self test will automatically fail. Please select a non-modem baud rate.

Parity

To change the parity:

1. Press the CLEAR key to step through the parity choices:

ODD
EVEN
NONE

2. When the desired parity is displayed, press the ENTER key to store the value and advance to the next parameter.

Address

To change the terminal address:

1. Press the CLEAR key to increment the address values from 01 to 32.
2. When the desired address is displayed, press the ENTER key to store the value and advance to the next parameter.

Terminal Application Type

The Terminal Application Type is used as a delimiter by the host for routing application information to the terminal. (Example: An access control terminal could have a different terminal type than a time and attendance terminal.) This value is typically left at A.

To change the terminal application type:

1. Press the CLEAR key to increment the type from A to J.
2. When the desired type is displayed, press the ENTER key to store the value and advance to the ATS NETWORK TEST.

ATS NETWORK TEST

ATS NETWORK TEST is a two-part test. The first allows the network wiring between the terminal and the host to be checked for open connections or wiring errors. This test requires that the ATS RS232 Communication Adapter, which is plugged into the host, be unplugged and pins 2 & 3 of the adapter jumped together (a metal paper clip should do the trick). Secondly, a local test can be performed on the terminal communication circuitry. This test will work for both RS232 and RS485 installations (RS485 installations require an ATS 232/485 Converter and power supply). To enter NETWORK TEST, press the ENTER key at the “**ATS NETWORK TEST**” prompt. The following message appears:

**SWITCH TEST SWITCH
TO USE POSITION**

Place the switch on the back of the terminal into the Use position. The Series 3610 performs a network test in which the terminal sends data up to the host, via the network cabling. Since a temporary jumper was installed in the ATS RS232 Communication Adapter, the data will be looped back to the terminal. The following should appear:

**NETWORK TEST PASS
ENTER TO RETEST**

To perform the local communication loop back, place the Test/Use switch back to the Test position and press the ENTER key. The following message should appear:

**NETWORK TEST PASS
ENTER TO RETEST**

Remove the jumper from the RS232 Communication Adapter and secure it back into the host port. Press the CLEAR key to advance to the next test.

ATS BATTERY TEST

The ATS BATTERY TEST checks the terminal battery backup option if installed. To enter this test, press the ENTER key at the “**ATS BATTERY TEST**” prompt. The following message should appear:

**BATTERY TEST PASS
ENTER TO RETEST**

Note: If the battery backup option is not installed the battery test will fail.
Press the CLEAR key to advance to the ATS DI-DO TEST.

ATS DI-DO TEST

The ATS DI-DO TEST is a two-part test that checks the terminal DATA IN/DATA OUT port connection by performing a loop back communication test on the port circuitry. To enter the ATS DI-DO TEST:

1. Press the ENTER key at the “ATS DI-DO TEST” prompt. The following message should appear:

**SWITCH TEST SWITCH
TO USE POSITION**

2. The enclosure must be opened to place the test switch into the Use position. Since no loop back jumper is installed during this phase of testing the following message will appear:

DI-DO TESTING

**DI-DO TEST FAILED
ENTER TO RETEST**

3. Place the Test/Use switch into the Test position. This will provide the terminal with its own loop back jumper. Re-assemble the enclosure and keypad assembly.
4. Press the ENTER key. The following message should appear:

**DI-DO TEST PASSED
ENTER TO RETEST**

5. Press the CLEAR key to advance to ATS RESTART MODE.

ATS RESTART MODE

The ATS RESTART MODE *clears all* transaction data and any download from memory. To restart the terminal:

1. Press the ENTER key to select the ATS RESTART MODE. The terminal displays:

**PRESS ENTER TO CLEAR
ALL TRANSACTION DATA**

2. Press the ENTER key. The terminal displays:

CLEAR FOR CYCLE TEST
(Note: Cycle test is for factory diagnostics only.)
ENTER FOR RESTART

3. Press the ENTER key. The terminal displays:

CLEARING MEMORY . . .

The green Valid LED will blink and the terminal will execute its power up sequence and return to the beginning of the Test Mode.

ATS AUX PORT TEST

The ATS AUX PORT TEST will automatically fail because the required loop back jumpers are not installed. If this test should need to be performed, contact factory for pin-out information.

To exit the Test Mode place the Test/Use switch in the Use position and press the CLEAR key. The terminal will execute its power up sequence. The terminal displays: "TERMINAL LOCKED" and can now accept a host download.

This completes the ACCU-RATE™ test and set-up.

Downloading the Series 3610

The Series 3610 terminal, when used with a standard Time and Attendance "C" application, can be downloaded with employee names, badge numbers, schedules, etc. These download commands and others are explained in the Time and Attendance Labor Traker command set manual. For further information refer to this manual.

MAINTENANCE

The Series 3610 is a maintenance-free data collection device. The only required procedure is periodic cleaning of the badge reader.

To clean the badge reader, swipe a pre-moistened (isopropyl alcohol) cleaning card through the reader several times. Low usage readers should be cleaned monthly. High usage readers should be cleaned weekly.

TROUBLESHOOTING GUIDE

Problem: Terminal does not power up and none of the status LEDs are lit.

Possible cause: No DC power is applied

Solution: Ensure primary side of DC power pack assembly is plugged into to a live AC outlet. Ensure secondary side of DC power pack assembly is plugged into the Time and Data Collection Terminal (DCT).

Solution: If remotely powered, check cable distance and any network power jumpers that may need repositioning.

Solution: Test the outlet by plugging in another appliance or check that the secondary supply is plugged into the terminal.

Solution: If all else fails, replace the power pack assembly.

Problem: Yellow Low Power indicator is lit.

Possible cause: Low or no DC power. (Optional battery is now providing power.)

NOTE: The terminal will operate for approximately 4-hours with a fully charged battery when primary voltage source is lost. After this, the terminal will power off. The yellow indicator light, located on the front of the terminal, will illuminate prior to the terminal blanking out.

Solution: Check output of 12-volt DC power pack.

Solution: Check for proper AC outlet voltage.

Possible cause: Terminal does not go blank after unplugging the battery connector.

Solution: Unplug and replace the power pack assembly.

Problem: Terminal is not communicating with Host.

Possible cause: Host Test/Use switch is in the Test position.

Solution: Place the Test/Use switch in the Use position.

Possible cause: DCT to Host communication cable is defective or unplugged on either end.

Solution: Verify that the cable is tested, plugged in on the host side, and is correctly wired to the interface board in the base of the 3610. (Ensure cable termination guidelines and lengths are observed.)

Solution: Ensure the application package is loaded and running on the host.

Possible cause: Communication parameters for the DCT do not match those of the Host.

Solution: Refer to the ACCU-RATE™ test and diagnostics section for set-up directions.

Problem: DCT does not accept badge data.

Possible cause: Bar code badge is not manufactured to proper specification.

Solution: Refer to vendor's and/or ATS specifications for manufacturing criteria.

Possible cause: Badge is being swiped in the wrong direction.

Solution: Ensure media faces to the right (away from keypad).

Possible cause: Badge reader needs cleaning.

Solution: Swipe a pre-moistened (isopropyl alcohol) cleaning card through the reader several times.

Possible cause: Badge number does not exist in validation file.

Solution: See supervisor

Note: If all solutions fail, try reading the badge in the ACCU-RATE™ test mode.

Problem: Terminal does not accept keypad input.

Possible cause: Keyed data does not exist in validation file.

Solution: See supervisor

Possible cause: Keypad connector is unplugged.

Solution: Test keypad in the ACCU-RATE™ test mode.

If all solutions have been explored and the problem still exists, contact the Accu-Time Product Service Department at (860) 870-5000 during normal working hours 9 AM to 5 PM—Monday through Friday. Prior to contacting Accu-Time, please have available the serial number and, if possible, the configuration number of the product. These numbers can be located on the terminal identification label.

NOTE: The DCT has no user serviceable parts. The Accu-Time terminal must be operated within the parameters included in this manual. Any operation performed contrary to these parameters will void the warranty.

FCC Statement

This equipment has been tested and found to comply with the limits for a Class A digital device pursuant to Part 15 of the FCC rules. These limits are designed to provide reasonable protection against harmful interference in a residential installation. This equipment generates, uses, and can radiate radio frequency energy and, if not installed and used in accordance with the instructions, may cause harmful interference to radio communications. However, there is no guarantee that interference will not occur in a particular installation. If this equipment does cause harmful interference to radio or television reception, which can be determined by turning the equipment off and on, the user is encouraged to try and correct the interference by one or more of the following measures:

- Reorient or relocate the receiving antenna.
- Increase the distance between the time clock and the receiver.
- Connect the equipment into an outlet on a circuit different from that which the receiver is connected.

FCC Warning: To assure continued FCC emission limit compliance, the user must use only the recommended shielded interfacing cable when connecting to a host computer. Also, any unauthorized changes or modifications to this equipment would void the user authority to operate this device.