

# **SERIES 5600**

## **TIME AND DATA COLLECTION TERMINAL**



**Accu-Time Systems, Inc.**

420 Somers Road, Ellington, CT 06029

Tel: (860) 870-5000 Fax: (860) 872-1511

Web Site: [www.accu-time.com](http://www.accu-time.com)



Copyright® 1998 Accu-Time Systems, Inc. Second Printing, 1999. Accu-Time is a registered trademark of Accu-Time Systems, Inc. The material contained in this manual is subject to change. No part of this manual may be reproduced or distributed in any form or by any means, or stored in any database or retrieval system, without Accu-Time's prior written permission. Accu-Time Systems, Inc. makes no warranty of any kind including, but not limited to, any implied warranties of merchantability, and fitness for a particular purpose in regard to this manual.

All Rights Reserved. Printed in the USA.

# ACCU-TIME® SERIES 5600

## TABLE OF CONTENTS

---

Introduction	1
Features	2
Specifications	3
Installation	4
ACCU-RATE™ Diagnostics	9
Ethernet Testing and Setup	14
Maintenance	17
Troubleshooting Guide	18
Ethernet Troubleshooting Guide	20

## INTRODUCTION

---

The Accu-Time Series 5600 is a true 'C' download programmable intelligent Time and Data Collection Terminal. The Series 5600 offers a large, capacitor backed, user memory base of up to 768K and is equipped with two full duplex RS232 Auxiliary ports and provisions for laser inputting. An additional DI/DO module with 6 Form 'C' relays transforms the Series 5600 into an Industrial Machinery Controller. In addition to operating in standard EIA communication formats, the Series 5600 is also TCP/IP Ethernet 10-base-T compatible. Among the many features of the 5600 are:

- ◆ **Multi-Media:** Can support most standard bar code formats including UPC, 128, 39, 2/5, I2/5 and more, as well as IATA Track I and ABA Track II magnetic stripe input.
- ◆ **Flexibility:** The Series 5600 can act as a stand alone time station or as part of a local or wide area network. The terminal can also interface with virtually any host hardware or software platform.
- ◆ **Custom Applications:** Custom programs and programmable function keys can provide users with the flexibility to create a variety of options.
- ◆ **Reliability:** A Real Time Clock (RTC) provides 12 or 24 hour time formats with quartz precision. An optional non-interruptible power supply (UPS) provides terminal operation for up to 4 hours during a power outage, for example. Data storage will be preserved for up to 4 days with the memory backup system.
- ◆ **Durability:** Environmental enclosure protects circuitry from environmental conditions such as extreme temperatures and airborne dust.

Versatility, Reliability and Affordability in a state-of-the-art ergonomically designed terminal and backed by the ACCU-TEAM.

## FEATURES

---

- Single or multi-clock environments on a variety of host platforms with application programs integrating the ATS DATA TRAKER™ family of modules.
- 128K Byte capacitor backed memory base, expandable to 768K
- Optional 64K Flash memory
- TCP/IP Ethernet 10-base-T compatible (802.3)
- EIA Standard RS232 or RS485 compatible
- On-board ACCU-RATE™ terminal set-up and diagnostics package
- Custom keypad legends with software defined function keys
- Tactile 45 key alphanumeric keypad
- 2 or 4 line by 40 character backlit Liquid Crystal Display
- Dual tone audible annunciator
- Integrated or External Bar Code slot readers
- Wand port for external digital wands
- Laser input capability
- Integrated Magnetic slot readers, RF ID technology
- 6-DI/DO ports for machinery control
- 2-full duplex RS232 Auxiliary ports
- Uninterruptible power source with on-board charger
- Die cast aluminum housing with steel key-lockable, tamper resistant base assembly
- CE Mark and FCC part 15 Certified

## SPECIFICATIONS

---

Display:	2 Line x 40 Character backlit super-twist LCD 4 Line x 40 Character backlit super-twist LCD
Clock:	12 or 24 hour-format-USA or International (quartz precision) Time stamp of data transactions
Indicators:	Yellow LED: low power indicator Two programmable LED indicators, red and green Diagnostic LEDs for Ethernet: Yellow = busy Green = linked Yellow = receive Red = transmit
Keypad:	Tactile 45 key alphanumeric Software defined function keys Custom user defined keypad legends
Memory:	128K Byte Expandable to 768K Byte of capacitor backed memory (3000 or greater employee base – program dependent) 64K Flash memory
Programming:	ATS DATA TRAKER modules, “C” programming language or third party custom application packages.
Interface:	TCP/IP Ethernet 10-base-T (802.3) EIA standard RS232 or RS485 (2 or 4 wire) Standard AT Command set for up to 2400-baud Modem operation (expanding 9600-baud rate with optional external modem)
Enclosure:	Die cast aluminum housing with steel key-lockable base assembly
Power:	+10 to 17 VDC (+12 VDC @ 400 milliamps nominal) Local, remote or centrally powered Non-interruptible power source with charger (optional)
Environment:	Operation: 32° to 110° F (0° to 43° C)
Certification:	CE Mark Certified (CE, RE, ESD, RS and CS) FCC part 15
Physical:	11.5” wide x 7.25” high x 3.4” deep. Weight: 5.3 lbs. (29.21 cm wide x 18.42 cm high x 8.64 cm deep. Weight: 2.4 kg)
Accessories:	Integrated Optical Bar Code or Magnetic slot readers RF ID readers, six form 'C' relay module Laser and CCD scanners, Digital Bar Code Wands External Optical Bar Code slot readers

## INSTALLATION

---

### GENERAL INSTALLATION GUIDELINES

#### Environment

Although the Series 5600 Time and Data Collection Terminal is a durable industrial-grade device, which will endure harsh environments, it never the less is an electronic device. Environmental constraints exist and care should be given when selecting a location for installing and operating the Series 5600.

The ATS<sup>®</sup> terminal is designed to operate indoors. Exposure to outdoor elements such as rain or snow will not only void the manufacturer warranty, but may cause damage to the device. The terminal should be mounted on a vibration free area. Select a location, which has adequate lighting and accessibility to operate the terminal safely.

#### Operating Parameters

Accu-Time<sup>®</sup> recommends that the Series 5600 operate in an ambient temperature range of between 32° and 110° Fahrenheit. Non-condensing humidity should be less than 95%. The RS232 Series 5600 must be located no greater than fifty (50) wire-feet from the host computer. EIA standards for RS232 protocol data transmission dictate this cable distance. Exceeding this requirement greatly increases the chances for continual data re-transmission, which may never be acknowledged.

The RS485 Series 5600 locally powered must be located no greater than five thousand (5000) wire-feet from the host computer. EIA standards for RS485 protocol data transmissions dictate this cable distance. Exceeding this requirement greatly increases the chances for continual data re-transmission, which may never be acknowledged.

The Ethernet Series 5600 may be located at any point within a TCP/IP Ethernet 10-base-T Network, providing the single segment length from the network hub does not exceed three hundred and twenty-eight (328) wire-feet. A typical topology for the Series 5600 in an Ethernet 10-base-T network is a star configuration.

## INSTALLATION

### Base

Locate a flat wall surface to accommodate the Series 5600. With terminal power being supplied locally, insure that a conventional 110VAC wall outlet, 220VAC in Europe and other areas, (check local electrical code requirements) is dedicated to accept the Series 5600 12VDC power pack assembly. The outlet should be no further than four (4) feet from the terminal.

With the supplied terminal mounting template, prepare the wall to accommodate mounting hardware (customer provided). Typical mounting height is forty-eight inches from floor to the terminal display (Compliant to the Americans with Disabilities Act). Observe OSHA and/or local safety codes when operating tools during all phases of installation. Attach the terminal wall mount to the flat wall surface. Select and remove one of the perforated knockouts on the wall mount, which will accommodate the data transmission and 12VDC power pack cable assemblies.

### Data Cable

For RS232 applications, ATS recommends using a modular telephone-type data cable. This eight- (8) conductor shielded flat cable has RJ-45 modular plugs on each end. For example, the fifty (50) foot ATS cable, part number 63-2003-02, may run along side base-moldings, walls, overheads, or in hostile environments through conduit tubing. One end of the cable terminates into the Series 5600 communication port while the other terminates into the host computer's serial port via an ATS RS232 Communication Adapter.

## RS232 SAMPLE INSTALLATION

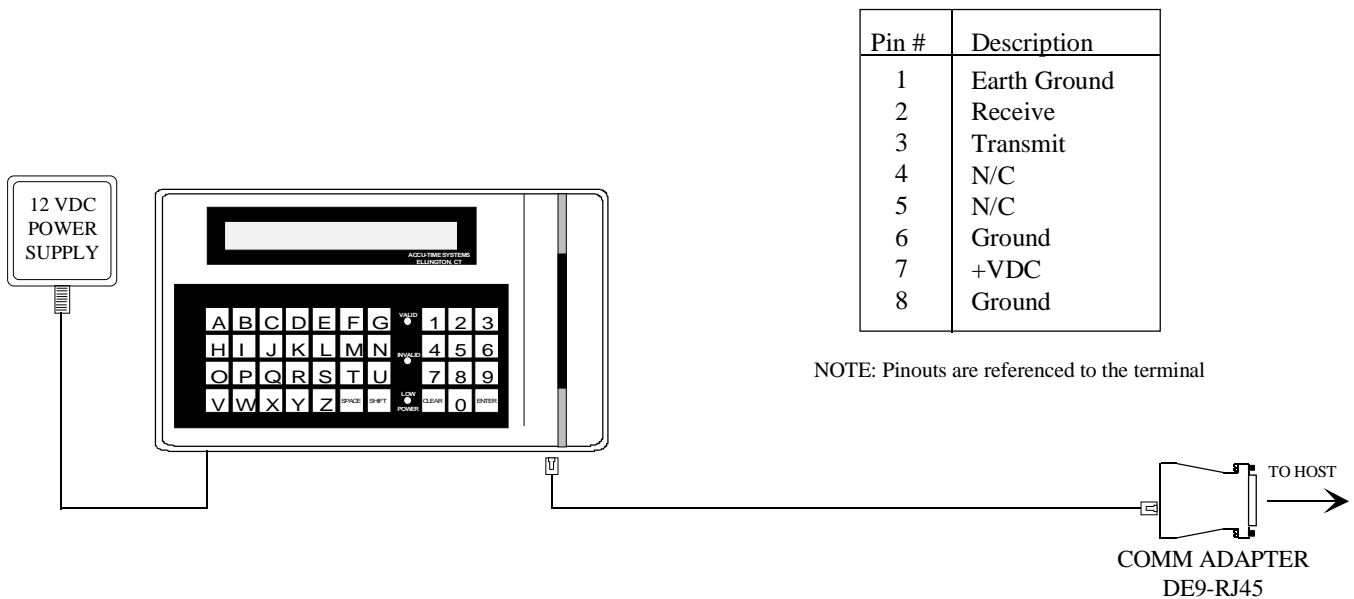

5K232PQ.DRW

For RS485 communication applications, ATS recommends using a twisted pair, data transmission trunk cable that adheres to the following specifications:

- Five conductor shielded 24-gage wire with a drain.**
- The impedance of the cable should be 100 Ohms.**
- The nominal capacitance between conductors should be 12.5 pico-farads per foot.**
- The jacket of the cable is typically PVC material.**

\*Note\* If the host is not equipped with an RS485 port, an ATS® RS232/485 Converter with 12 volt power pack assembly will convert the terminal communication lines to RS232 levels. The host output of the RS232/485 Converter plugs directly into the ATS® RS232 Communication Adapter.

RS485 allows for the Series 5600 to be used in multi-dropped networks. Thirty-two (32) terminals can be supported on a single host communication port. The use of ATS® Series 1000 Network Controllers allow up to five hundred and twelve (512) terminals on a single host communication port.

### MULTI-CLOCK - RS485 SAMPLE INSTALLATION

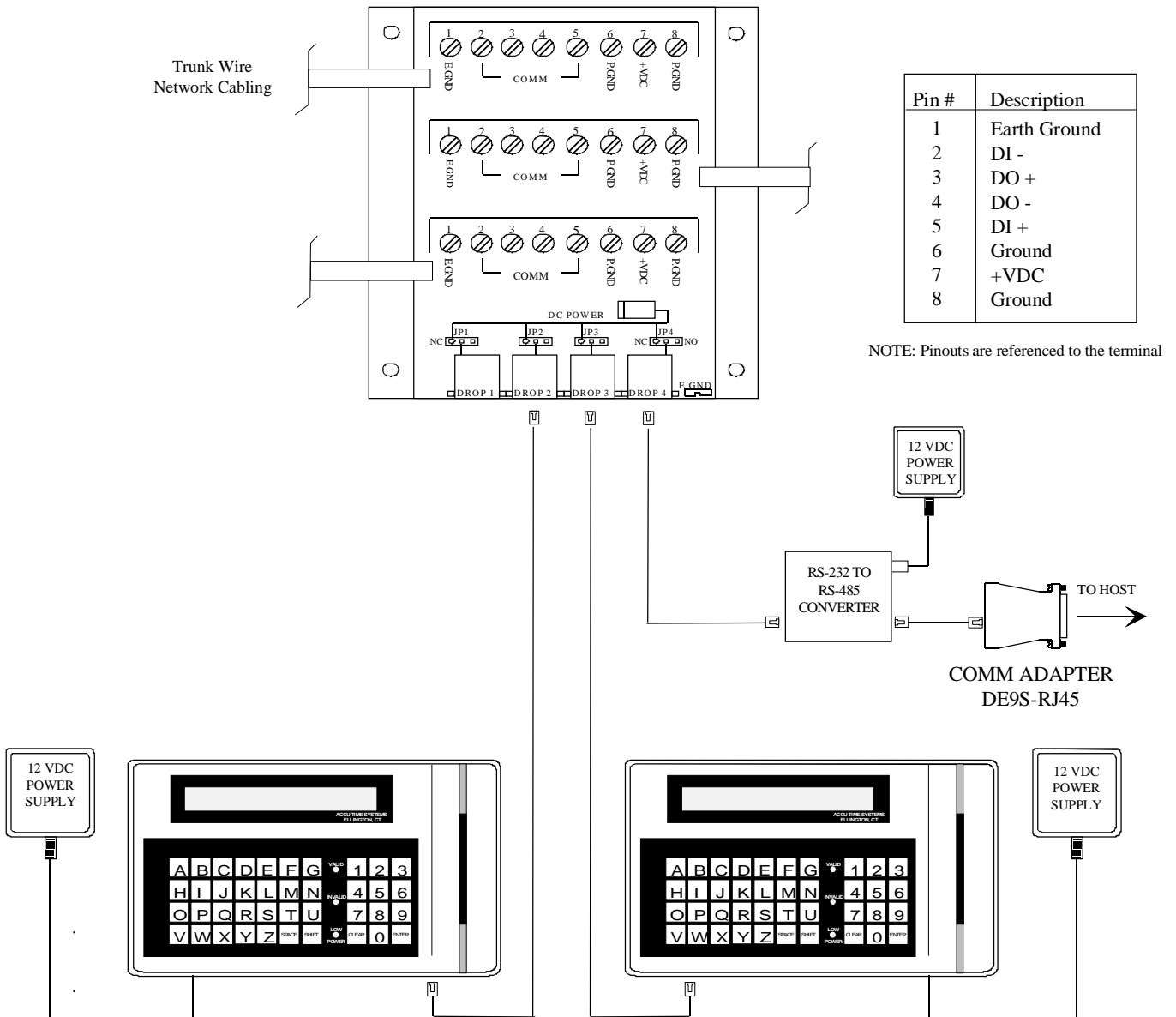

For Ethernet communication applications, ATS® recommends using a CATEGORY 5 unshielded twisted pair high-speed data transmission cable. One end of the 568B RJ45 terminated cable is plugged into the Series 5600 Ethernet port, while the other end is plugged into the network hub.

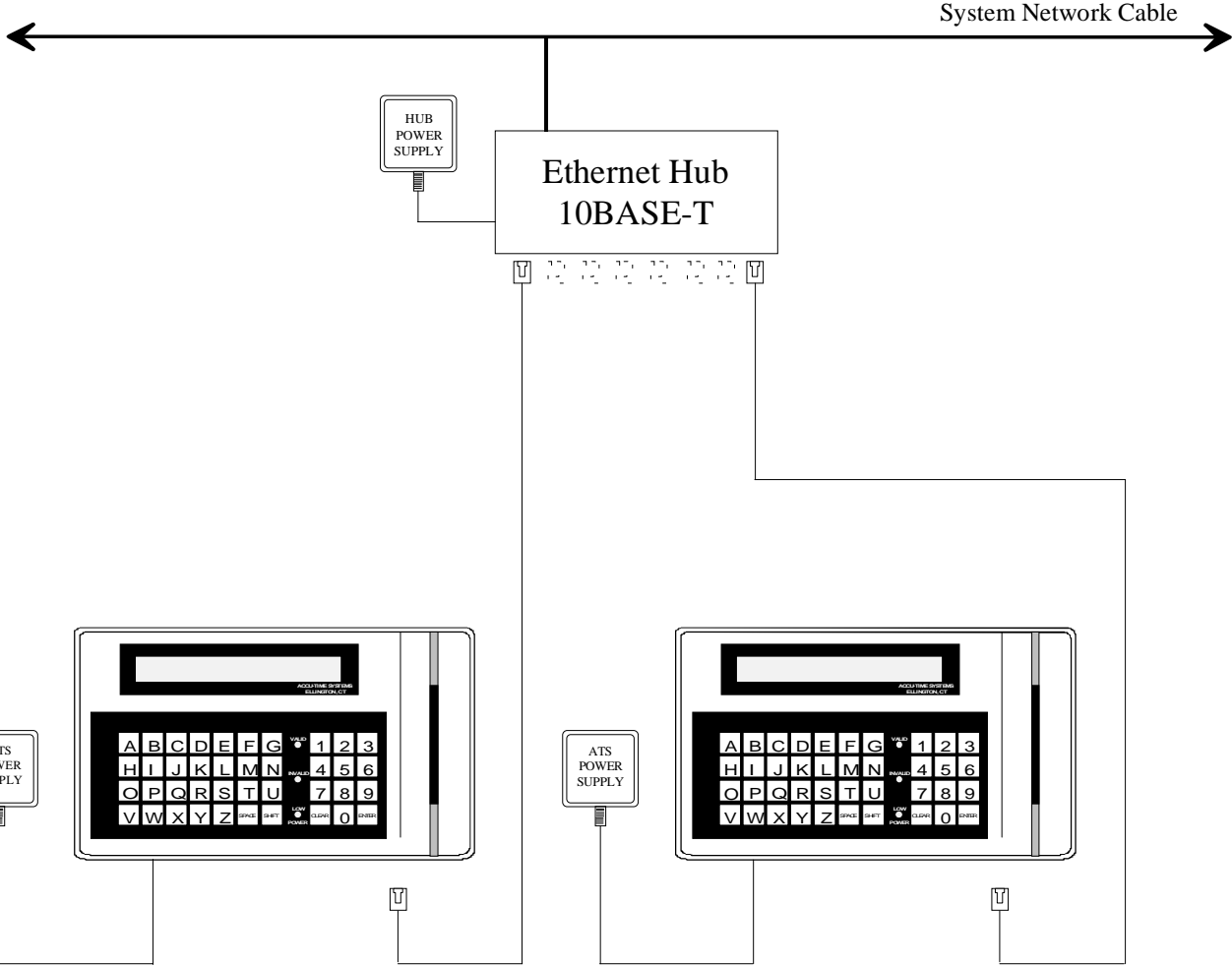
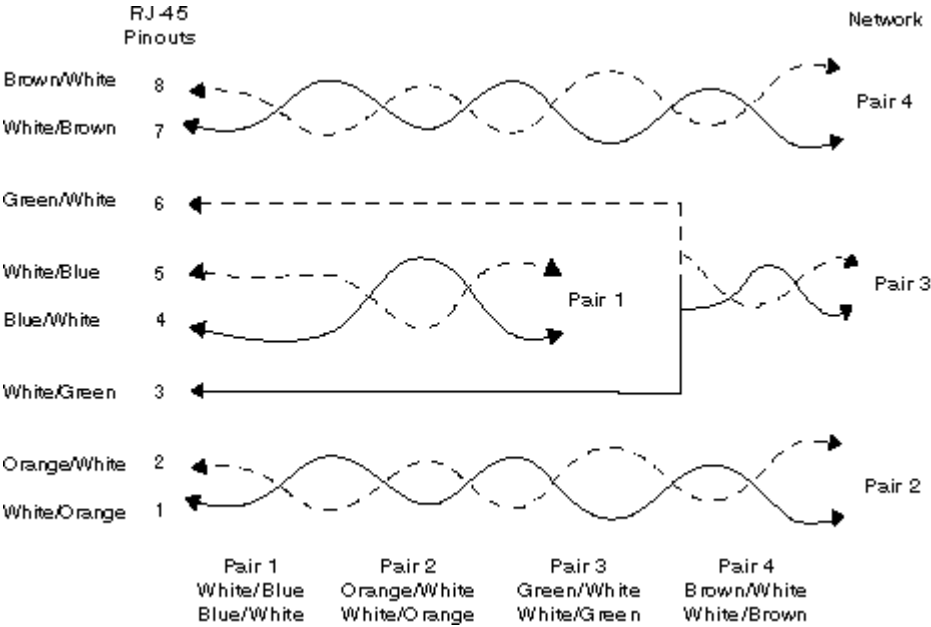

## Terminal Face

Align the faceplate of the Series 5600 over the wall mount assembly.

Plug the data cable into the eight- (8) position communication port of the Series 5600. Attach the output of the 12VDC power pack assembly into the power jack of the Series 5600. Plug the primary of the power pack assembly to the conventional wall outlet.

With the terminal's USE/TEST switch in the USE mode, attach the face to the wall mount assembly. Secure the assemblies with the key or screw lock.

The Series 5600 will power-up and display the on-line default message. (Refer to the ATIS SETUP MODE section of this manual for terminal communication setup parameters) Attach the remaining end of the data cable into the host computer port. The Series 5600 is now ready for operation.

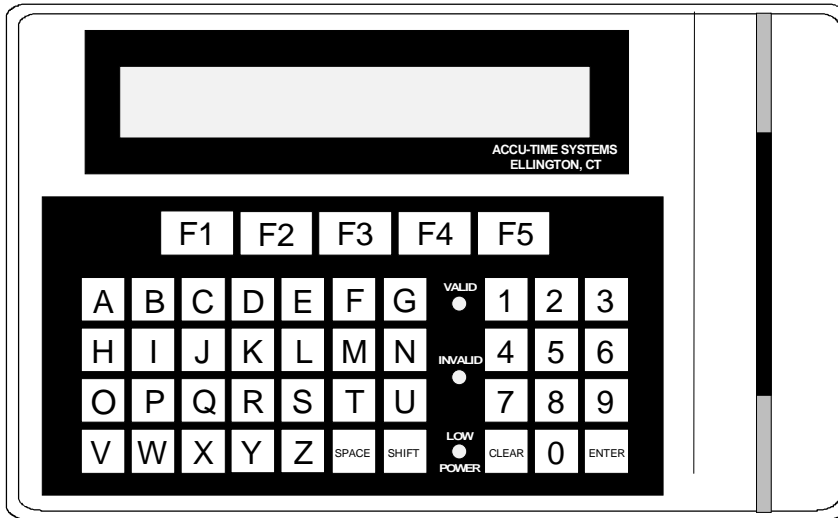

(Front of Terminal)

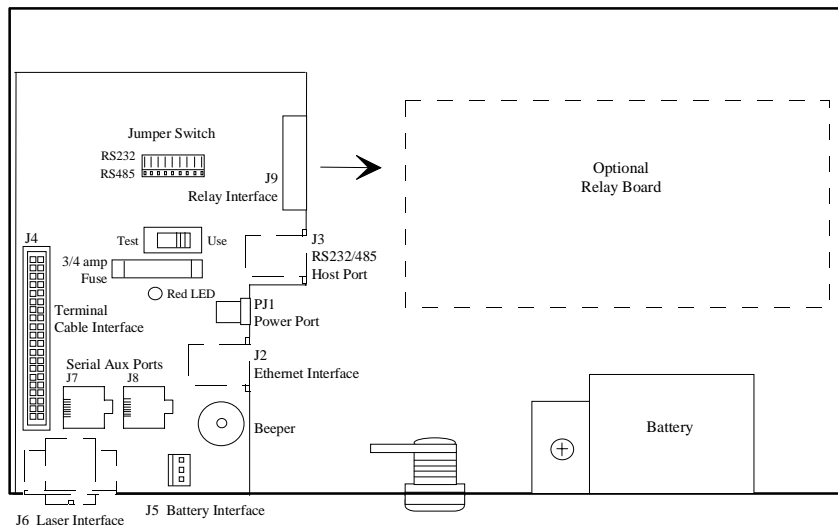

(Back Chassis)

### Serial Aux 1 and 2 Pin Outs (J7, J8)

Pin #	Description
1	Earth Ground
2	RXD ←
3	TXD →
4	CTS ←
5	RTS →
6	Ground
7	VDC
8	Earth Ground

### Laser Connector Pin Outs (J6)

Pin #	Description
1	ST Scan
2	Bar Data
3	ACK
4	N/C
5	Trigger
6	Scan EN
7	Ground
8	Shield
9	+5VDC

### \*Wand Connector Pin Outs

Pin #	Description
1	Earth Ground
2	Ground
3	+ 5 VDC
4	+ 5 VDC
5	Wand Data
6	N/C

wandpo

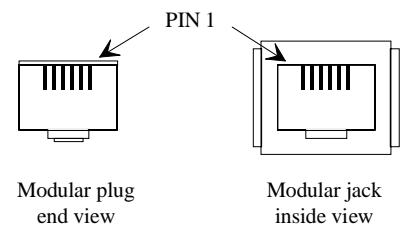

\*The wand connector is located on the back of the terminal.

## ACCU-RATE™ SET-UP AND DIAGNOSTICS

---

### POWER UP

To power up the Series 5600, a 12VDC at 1 amp nominal power source must be applied to the terminal power jack. The Series 5600, with the TEST/USE switch placed in the USE mode, beeps, executes a power up sequence and displays the message “**TERMINAL LOCKED**”.

### ACCESSING TEST MODE

To access the test mode:

- 1) Unlock the base assembly on the Series 5600.
- 2) Locate the Test/Use switch on the I/O board assembly.
- 3) Slide the switch into the TEST position. The Series 5600 will display “**ATS TEST MODE**”.
- 4) By pressing the CLEAR key, the user can step through the selections. (\*NOTE\* Test mode may be exited at any time by placing the Test/Use switch back to the USE position and pressing the CLEAR key).

### SELECTIONS:

- **ATS TEST MODE:** Tests the Keypad, Display, Memory, Real Time Clock, Bar Code or Magnetic Slot reader and Bar Code Wand circuitry.
- **ATS SET-UP MODE:** Configures the communication parameters—Baud Rate, Parity Bit, Terminal Address, and Terminal Application Type.
- **ATS NETWORK TEST:** Performs a terminal to host communication loop-back test. Verifies integrity of cabling.
- **ATS BATTERY TEST:** Checks the terminal battery back up option.
- **ATS DI-DO TEST:** Checks the Digital Input/Digital Output auxiliary port by performing a loop-back test.
- **ATS RESTART MODE:** Resets the terminal, clears all data from memory and performs a power-up sequence.
- **ATS AUX PORT TEST:** Checks the auxiliary DI/DO and bi-directional serial auxiliary port.

## ATS TEST MODE:

ATS TEST MODE checks the functionality of the terminal Keypad, Memory, Real Time Clock, Bar Code or Magnetic Slot reader and Bar Code Wand circuitry.

To enter the TEST MODE, press the ENTER key. The message “**ATS TEST MODE**” appears on the top line of the display. The 2<sup>nd</sup> line of the display indicates the two program (EPROM) numbers. By pressing the ENTER key the following information appears:

**ATS TEST MODE (XXX) (YY)**

-----

The terminal displays **ATS TEST MODE** on the top line followed by two sets of numbers. The first number (XXX) indicates the amount of memory installed (in Kilobytes). The right most number (YY) indicates the terminals Real Time Clock incrementing in seconds (00-59).

### Testing the Keypad

At this time the user may test the keypad assembly. Each time a key is pressed the terminal will beep and the key value will appear on the 2<sup>nd</sup> line of the display. Press the ENTER key. The message “**KEY INPUT ACCEPTED**” is displayed. Each time the ENTER key is pressed an internal test of the terminal’s communication port is performed. If an error is detected the message “**COMM PORT FAIL**” will display, the invalid light will flash and the negative acknowledgement beeper tone will cycle. This message will continue until power is removed from the terminal.

### Testing the Badge Reader

ATS<sup>®</sup> TEST MODE accepts inputs from slot readers (optical or magnetic) and bar code wands. To test the reader, simply swipe the applicable bar code or magnetic stripe badge. The terminal beeps and displays the badge data.

To test the bar code wand, the user lightly drags the tip of the wand across the bar code badge or label. The wand should be positioned in the hand, similar to that of a pen or pencil, at an approximate 30° angle. Begin the scanning process by dragging the wand horizontally, in a straight line, and at a constant speed across the entire label area. Each bar code label includes a preceding and trailing ¼ inch quiet zone. This area which is free of any marks or bars is a part of the bar code label and must be included when scanning the label. Upon the successful completion of a bar code read the terminal will beep and display the data.

To proceed to the ATS SETUP MODE press the CLEAR key.

## ATS SETUP MODE

ATS SETUP MODE allows the operator to configure the terminal for communications with the host computer. The Series 5600 default parameters are set as follows:

Baud Rate	9600
Parity	ODD
Address	01
Terminal Application Type	A

To enter the ATS SETUP MODE, press the ENTER key at the “**ATS SETUP MODE**” display prompt. (Prior to pressing the ENTER key, the 2<sup>nd</sup> line of the display will indicate the current terminal setup values)

## **Baud Rate**

To change the terminal baud rate:

1. Press the CLEAR key to step through the baud rate choices:

19200  
9600  
4800  
2400  
1200  
M1200 Not applicable  
M2400 Not applicable

2. When the desired baud rate is displayed, press the ENTER key to store the value and advance to the next parameter.

*NOTE: No modem is installed, therefore, if the modem baud rate is selected, the modem self test will automatically fail.*

## **Parity**

To change the parity:

1. Press the CLEAR key to step through the parity choices:

ODD  
EVEN  
NONE

2. When the desired parity is displayed, press the ENTER key to store the value and advance to the next parameter.

## **Address**

To change the terminal address:

1. Press the CLEAR key to increment the address values from 01 to 32.
2. When the desired address is displayed, press the ENTER key to store the value and advance to the next parameter.

## **Terminal Application Type**

The Terminal Application Type is used as a delimiter by the host for routing application information to the terminal. For example, an access control terminal could have a different terminal type than a time and attendance terminal.

To change the terminal application type:

1. Press the CLEAR key to increment the type from A to J.
2. When the desired type is displayed, press the ENTER key to store the value and advance to the ATS NETWORK TEST.

## **ATS NETWORK TEST**

ATS NETWORK TEST is a two-part test. The first allows the network wiring between the terminal and the host to be checked for open connections or wiring errors. This test requires that the ATS RS232 Communication Adapter which is plugged into the host, be unplugged and pins 2 & 3 of the adapter jumped together (a paper clip should do the trick). Secondly, a local test can be performed on the terminal communication circuitry. This test will work for both RS232 and RS485 installations (RS485 installations require an ATS<sup>®</sup> 232/485 Converter). To enter NETWORK TEST, press the ENTER key at the “**ATS NETWORK TEST**” prompt. The following message appears:

**SWITCH TEST SWITCH  
TO USE POSITION**

Place the switch on the back of the terminal into the USE position. The Series 5600 performs a network test in which the terminal sends data up to the host, via the network cabling. Since a temporary jumper was installed in the ATS RS232 Communication Adapter, the data will be looped back to the terminal. The following message should appear:

**NETWORK TEST PASS  
ENTER TO RETEST**

To perform the local communication loop back, place the USE/TEST switch back to the TEST position and press the ENTER key. The following message should appear:

**NETWORK TEST PASS  
ENTER TO RETEST**

Remove the jumper from the RS232 Communication Adapter and secure it back into the host port. Press the CLEAR key to advance to the next test.

## **ATS BATTERY TEST**

The ATS BATTERY TEST checks the terminal battery backup option if installed. To enter this test, press the ENTER key at the “**ATS BATTERY TEST**” prompt. The following message should appear:

**BATTERY TEST PASS  
ENTER TO RETEST**

*Note: If the battery backup option is not installed, the battery test will fail.*

Press the CLEAR key to advance to the ATS DI-DO Test.

## **ATS DI-DO TEST**

The ATS DI-DO Test is a two-part test that checks the terminal auxiliary DATA IN/DATA OUT port connection by performing a loop back communication test on the port circuitry. To enter the ATS DI-DO Test:

1. Press the ENTER key at the “**ATS DI-DO TEST**” prompt. The following message should appear:

**SWITCH TEST SWITCH  
TO USE POSITION**

2. Place the test switch into the USE position. Since no loop back jumper is installed during this phase of testing the following message will appear:

**DI-DO TESTING**

**DI-DO TEST FAILED  
ENTER TO RETEST**

3. Place the TEST/USE switch into the TEST position. This will provide the terminal with its own loop back jumper.
4. Press the ENTER key. The following message should appear:

**DI-DO TEST PASSED  
ENTER TO RETEST**

5. Press the CLEAR key to advance to ATS RESTART MODE.

**ATS RESTART MODE**

The ATS RESTART MODE *clears all* transaction data and any download from memory. To restart the terminal:

1. Press the ENTER key to select the ATS RESTART MODE. The terminal displays:

**PRESS ENTER TO CLEAR  
ALL TRANSACTION DATA**

2. Press the ENTER key. The terminal displays:

**CLEAR FOR CYCLE TEST**  
*(Note: Cycle test is for factory diagnostics only)*  
**ENTER FOR RESTART**

3. Press the ENTER key. The terminal displays:

**CLEARING MEMORY. . .**

The green Valid LED will blink and the terminal will execute its power up sequence and return to the beginning of the Test Mode.

4. To exit the Test Mode, place the TEST/USE switch to the USE position and press the CLEAR key. The terminal will execute its power up sequence. The terminal displays: "**TERMINAL LOCKED**" and can now accept a host download.

**ATS AUX PORT TEST**

The ATS AUX PORT TEST will automatically fail because the required loop back jumpers are not installed. If this test should need to be performed, contact factory for pin-out information.

To exit the Test Mode, place the Test/Use switch in the Use position and press the CLEAR key. The terminal will execute its power up sequence. The terminal displays: "TERMINAL LOCKED" and can now accept a host download.

**This completes the ACCU-RATE™ test and set-up**

## ACCU-RATE™ ETHERNET SET-UP AND DIAGNOSTICS

---

ATS TEST MODE checks the ETHERNET circuitry installed in the Time and Data Collection Terminals. To accurately test this circuit the following sequential steps should be adhered to.

*NOTE: The Ethernet communication cable must be connected to the Time and Data Collection Terminal with running Host software for this operation to be successful.*

With the “TEST MODE” message in the terminal display, press the CLEAR key five (5) times. The message “ATS RESTART MODE” appears on the top line of the display. Press the ENTER key three (3) times to clear all memory prior to testing the ETHERNET circuit. **(Omitting this step greatly increases the chances of unreliable test results in the ETHERNET circuit).** After resetting the terminal will again display “TEST MODE”.

Press the CLEAR key one (1) time. The message “ATS SETUP MODE” followed by: **TERM 000.000.000.000** displayed for one (1) second  
Followed by: **HOST 000.000.000.000** displayed for one (1) second  
Followed by: **GATE 000.000.000.000** displayed for one (1) second  
(This message will only appear if the gate address was previously loaded.)  
Followed by: **MASK 000.000.000.000** displayed for one (1) second  
Followed by: **BROADCAST ENABLED** or **DISABLED** displayed for one (1) second  
Followed by: **APP ACK ENABLED** or **DISABLED** displayed for one (1) second  
Followed by: **WATCHDOG ENABLED** or **DISABLED** displayed for one (1) second

The above sequence will repeat itself until either the CLEAR or ENTER key is pressed. Pressing the CLEAR key will bypass the test. Pressing the ENTER key will enable the test.

Press the ENTER key. The following message will be displayed:

**TERMINAL IP ADDRESS      ###. ###. ###. ###. \_ \_ \_**

This is the Time and Data Collection unit’s unique Internet Protocol address. (See your network administrator for assignment.)

Enter, via the terminal’s keypad assembly, the numeric IP Terminal address in blocks of three followed by the ENTER key. Once all four octets are entered the following message will be displayed:

**HOST IP ADDRESS            ###. ###. ###. ###. \_ \_ \_**

This is the Host’s unique **Internet Protocol** address. (See your network administrator for assignment.)

Enter the numeric IP Host address in blocks of three followed by the ENTER key. Once all four blocks are entered the following message will be displayed:

**NETWORK MASK            ###. ###. ###. ###. \_ \_ \_**

This is the Subnet Mask used for channeling. (See your network administrator for assignment).

Enter the numeric Mask address in blocks of three followed by the ENTER key. Once all four blocks are entered the following message will be displayed:

**HIT ENTER IF DEFAULT ROUTE REQUIRED**

If a Router or Gateway is required press the ENTER key. The following message will be displayed:

**ROUTER IP ADDRESS ###. ###. ###. ###. \_ \_ \_**

This is the system Router used for directing Internet traffic among a variety of Hosts. (See your network administrator for assignment.) Enter the numeric Router or Gateway address in blocks of three followed by the ENTER key.

The following message allows an enablement of the Broadcast Receive command. If this function is disabled, the terminal will ignore all broadcast packets.

**HIT ENTER TO ENABLE BROADCAST RECEIVE**

Disabling Broadcast Receive may be accomplished by pressing the CLEAR key (recommended for networks with heavy traffic). Upon disablement, only devices connected to the same IP address will be able to “Ping” terminals.

The Application Acknowledgement message assures that the Host has received the last transaction, which enhances data integrity by affirming that the transaction has not been held up in a router/gateway or lost. The terminal will display the following:

**HIT ENTER TO ENABLE APPLICATION ACK**

Application Acknowledgement may be disabled by pressing the CLEAR key.

The next message, TCP/IP Watchdog, provides a “soft restart” if the connected terminal has not communicated with the Host for approximately ten- (10) minutes. The terminal will display the following message:

**HIT ENTER TO ENABLE TCP/IP WATCHDOG**

Pressing the CLEAR key will disable TCP/IP Watchdog.

The following message allows for Ethernet communication connection.

**ENETADD=XXXXXXXXXXXXHIT ENTER TO CONNECT**

The **XXXXXXXXXXXX** represents the unique Ethernet address programmed into the EPROM by the factory.

If a Router is not required Press the CLEAR key. The following message will be displayed:

**ENETADD=XXXXXXXXXXXXHIT ENTER TO CONNECT**

The **XXXXXXXXXXXX** represents the unique Ethernet address programmed into the EPROM by the factory.

Press the ENTER key or the CLEAR key if connection is not required. The terminal will briefly display an initializing message followed by:

**CONNECTING TO SERVER**

If the connection to the server was successful the following message is displayed:

**CONNECTION COMPLETE**

If the connection to the server was not successful the following message is displayed:

**CONNECTION FAILED!! HIT ENTER TO CONNECT**

Press the ENTER key. The terminal will display the following:

**CLOSING CONNECTION BEFORE RECONNECTION**

Followed by the brief initializing message and connecting message:

### **CONNECTING TO SERVER**

At this time the terminal will either complete the connection or fail.

If a connection failure occurs after numerous attempts, see the troubleshooting section of this manual for further assistance.

*This completes the ACCU-RATE™ ETHERNET test.*

### **Downloading the Series 5600**

The Series 5600 terminal, when used with the standard Time and Attendance "C" application, can be downloaded with employee names, badge numbers, schedules, etc. These download commands and others are explained in the ATS DATA TRAKER™ command set manual. For further information refer to this manual.

## **MAINTENANCE**

---

The Series 5600 is a maintenance-free data collection device. The only required procedure is periodic cleaning of the badge reader.

To clean the badge reader, swipe a pre-moistened (with Isopropyl alcohol) cleaning card through the reader several times. Low usage readers should be cleaned monthly. High usage readers should be cleaned weekly.

## TROUBLESHOOTING GUIDE

---

**Problem:** Terminal does not power up and none of the status LEDs are lit.

Possible cause: No DC power applied

*Solution:* Ensure primary side of DC power pack assembly is plugged into a live AC outlet. Ensure secondary side of DC power pack assembly is plugged into the Time and Data Collection Terminal (DCT).

**Problem:** Terminal display is blank (no character or backlight).

Possible cause: The primary of the power pack assembly is not plugged into an AC-wall outlet.

*Solution:* Test the outlet by plugging in another appliance or check that the secondary supply is plugged into the terminal.

*Solution:* If all else fails, replace the power pack assembly.

**NOTE:** If the battery backup option is installed, the terminal will operate for approximately 4-hours when the primary voltage source is lost. After this, the terminal will power off. The yellow indicator light, located on the front of the terminal, will illuminate prior to the terminal blanking out.

**Problem:** Yellow Low Power indicator is lit.

Possible cause: Low DC power is attached.

*Solution:* Replace 12-volt DC power pack.

Possible cause: Terminal does not go blank after unplugging the battery connector.

*Solution:* Unplug and replace the power pack assembly.

**Problem:** Terminal is not communicating with Host.

Possible cause: The terminal TEST/USE switch is in the TEST position

*Solution:* Place the TEST/USE switch is in the USE position.

Possible cause: DCT to Host communication cable is defective or unplugged on either end.

*Solution:* Verify cable is tested and plugged into both ends.  
(Ensure cable termination guidelines and lengths are observed.)

*Solution:* Ensure the application package is loaded and running on the host.

Possible cause: Communication parameters for the DCT do not match those of the Host.

*Solution:* Refer to the ACCU-RATE™ test and diagnostics section for set-up directions.

**Problem:** DCT does not accept badge data.

Possible cause: Bar code badge is not manufactured to proper specification.

*Solution:* Refer to vendor's specifications for manufacturing criteria.

Possible cause: Badge is being swiped in the wrong direction.

*Solution:* Ensure media faces to the right (away from the keypad).

Possible cause: Badge reader needs cleaning.

*Solution:* Swipe a pre-moistened (isopropyl alcohol) cleaning card through the reader several times.

Possible cause: Badge number does not exist in validation file.

*Solution:* See Supervisor

*Note:* If all solutions fail try reading badge in the ACCU-RATE™ test mode.

**Problem:** Terminal does not accept keypad input.

Possible cause: Keyed data does not exist in validation file

*Solution:* See Supervisor

Possible cause: Keypad connector is unplugged.

*Solution:* Test keypad in the ACCU-RATE™ test mode.

If all solutions have been explored and the problem still exists, contact the Accu-Time® Product Service Department at (860) 870-5000 during normal working hours 9 AM to 5 PM- Monday through Friday. Prior to contacting Accu-Time®, please have available the serial number and, if possible, the configuration number of the product.

*NOTE: The DCT has no user serviceable parts. The Accu-Time® terminal must be operated within the parameters included in this manual. Any operation performed contrary to these parameters will void the warranty*

## ETHERNET TROUBLESHOOTING GUIDE

---

### POWER RELATED

**Problem:** The terminal display is blank (no characters or backlight).

Possible cause: The primary of the power pack assembly is not plugged into an AC-wall outlet.

*Solution:* Check the outlet, both ends of the power pack, and if it is a 12VDC power pack.

*Solution:* If all else fails, replace the power pack.

**NOTE:** If the battery backup option is installed, the terminal will operate for approximately 4-hours when the primary voltage source is lost. After this, the terminal will power off. The yellow indicator light, located on the front of the terminal, will illuminate prior to the terminal blanking out.

**Problem:** The low power (yellow) indicator LED is activated.

Possible cause: Outlet or power pack problem.

*Solution:* Perform the above solution if the terminal display goes blank upon removal of the battery connector.

### COMMUNICATION RELATED

**Problem:** The terminal is not communicating with the host.

Possible cause: Communication parameters were not previously set.

*Solution:* Place terminal in Test Mode and step through ACCU-RATE™ Test procedures. The network administrator would provide the following:

- IP address to be assigned to the terminal
- IP address of the host to which the terminal can connect
- Network Mask (example 255.255.255.0)
- Gateway or Router address (if required)

*Solution:* If parameters are set, place terminal in Use Mode and perform a "ping" on the terminal.

*Solution:* Verify activity of LEDs located on the bottom of the terminal.

*Solution:* Verify that the cable is plugged into both ends (terminal and hub).

*Solution:* Verify that the single segment cable length is equal or less than the specified 328 feet. The cable should also be a 10-base-T category 4 or 5 twisted pair high-speed data transmission cable with both ends properly crimped.

*Solution:* Insure application package is loaded and running on the host.

**Yellow:** terminal is BUSY processing

**Green:** terminal is LINKED to host

**Yellow:** terminal data is being RECEIVED

**Red:** terminal data is being TRANSMITTED

**Problem:** A previously working terminal now is not operational.

Possible cause: TEST/USE switch is not in the Use position.

*Solution:* Place TEST/USE switch in Use position.

Possible cause: Cables not plugged in or host application software not operational.

*Solution:* Insure that all connections are made and that the host software application is functional. If possible, take a known working terminal, re-address it for this particular node and determine if the problem is related to the terminal, installation or host.

#### PERIPHERAL FAILURE

**Problem:** Bar code reader does not work.

Possible cause: The employee badge has not been added to the application database.

*Solution:* Place the TEST/USE switch into the Test position and swipe test badges to verify reader functionality.

*Solution:* If the reader works in the Test Mode and not in the Use Mode, verify that the employee badge has been added to the application database.

**Problem:** Keypad does not work.

Possible cause: Keypad function has been disabled in the application.

*Solution:* Place the TEST/USE switch to the Test Mode and press random keys to verify keypad functionality.

*Solution:* Insure that the keypad function within the application is activated.

**If neither the standard nor Ethernet troubleshooting guide is of any help, please contact the Accu-Time Product Service Center, (860) 870-5000, for further assistance.**

#### FCC Statement

---

This equipment has been tested and found to comply with the limits for a Class A digital device pursuant to Part 15 of the FCC rules. These limits are designed to provide reasonable protection against harmful interference in a residential installation. This equipment generates, uses, and can radiate radio frequency energy and, if not installed and used in accordance with the instructions, may cause harmful interference to radio communications. However, there is no guarantee that interference will not occur in a particular installation. If this equipment does cause harmful interference to radio or television reception, which can be determined by turning the equipment off and on, the user is encouraged to try to correct the interference by one or more of the following measures:

- \* Reorient or relocate the receiving antenna.
- \* Increase the distance between the time clock and the receiver.
- \* Connect the equipment into an outlet on a circuit different from that which the receiver is connected.

**FCC Warning:** To assure continued FCC emission limit compliance, the user must use only the recommended shielded interfacing cable when connecting to a host computer. Also, any unauthorized changes or modifications to this equipment would void the user authority to operate this device.

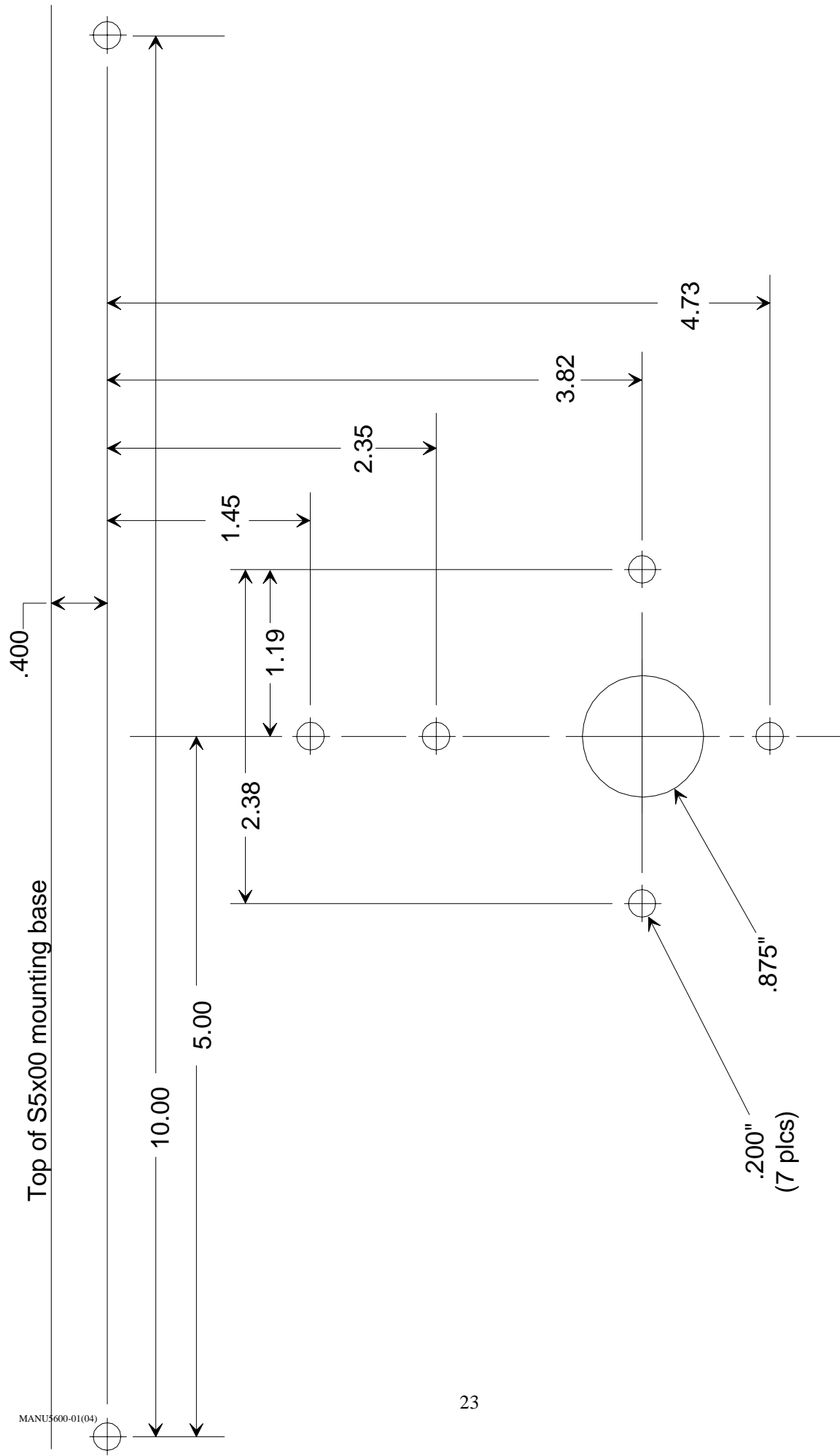

# 5000 Series Mounting Template